

KATALOG STĚRAČŮ **RG-FLEX**

STÍRACÍ SYSTÉM PRO DOPRAVNÍ PÁSY

ROST
GROUP

VÝROBA A SERVIS ČISTÍCIHO SYSTÉMU DOPRAVNÍCH PÁSŮ

SPODNÍ STĚRAČ DP LP UH

−40 °C +150 °C

PEVNÉ NAPÍNÁNÍ STĚRAČE

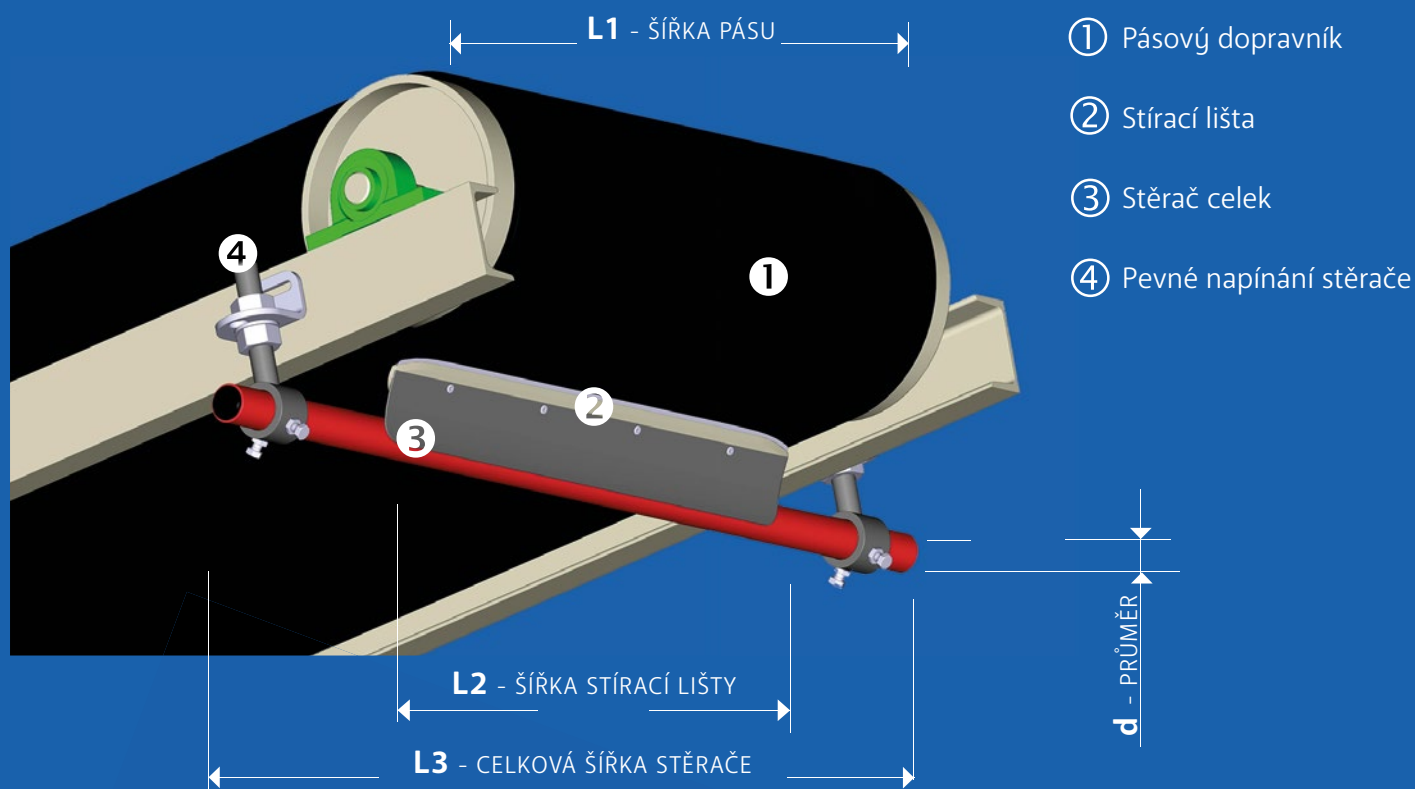

PEVNÉ NAPÍNÁNÍ- SESTAVA STĚRAČE

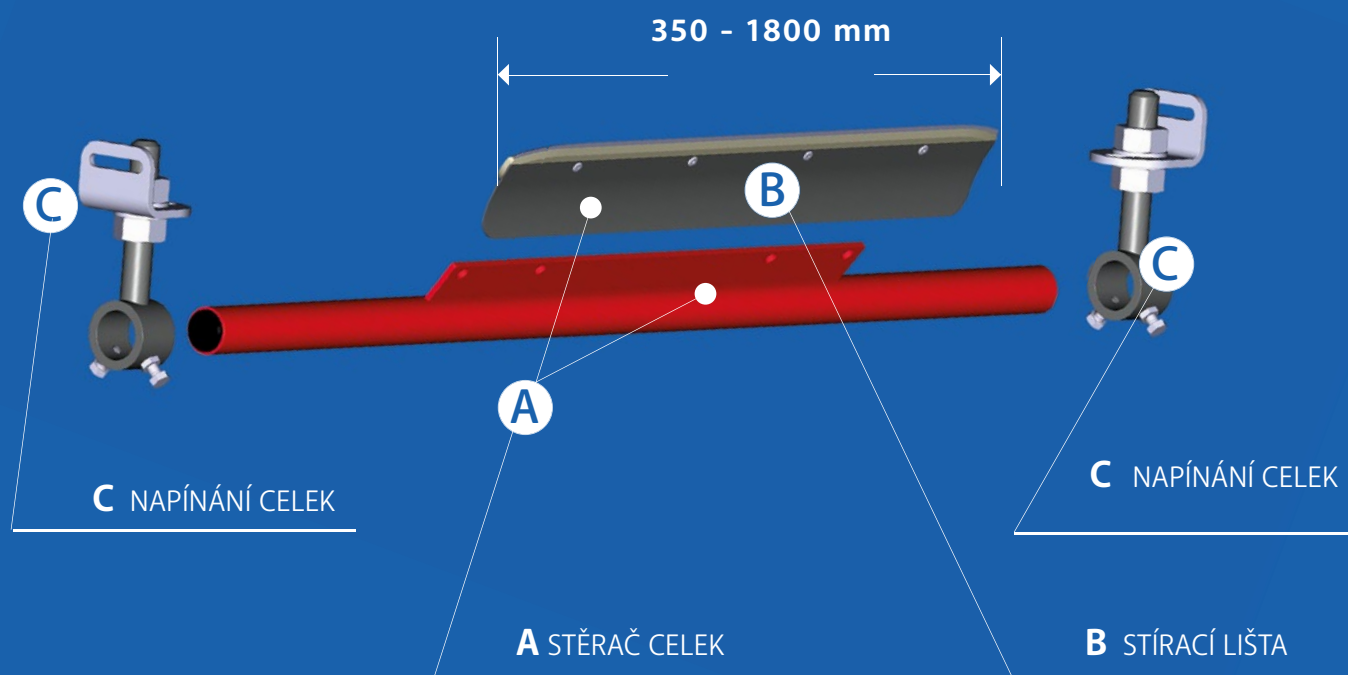

SPODNÍ STĚRAČ DP LP UH

PARAMETRY

| L1 (mm) | L2 (mm) | L3 (mm) | ∅ d (mm) | A | B |
|------------|------------|------------|-------------|----------------|----------------|
| 400 | 350 | 900 | 48 | 11 310 - 350 | 11 320 - 350 |
| 500 | 450 | 1 000 | | 11 310 - 450 | 11 320 - 450 |
| 650 | 550 | 1 200 | | 11 310 - 550 | 11 320 - 550 |
| 650 | 600 | 1 200 | | 11 310 - 600 | 11 320 - 600 |
| 800 | 700 | 1 300 | 48 | 11 310 - 700 | 11 320 - 700 |
| 800 | 750 | 1 300 | | 11 310 - 750 | 11 320 - 750 |
| 1 000 | 900 | 1 500 | | 11 310 - 900 | 11 320 - 900 |
| 1 000 | 950 | 1 500 | | 11 310 - 950 | 11 320 - 950 |
| 1 200 | 1 050 | 1 700 | 60 | 11 310 - 1 050 | 11 320 - 1 050 |
| 1 200 | 1 125 | 1 700 | | 11 310 - 1 125 | 11 320 - 1 125 |
| 1 400 | 1 200 | 1 900 | | 11 310 - 1 200 | 11 320 - 1 200 |
| 1 400 | 1 300 | 1 900 | | 11 310 - 1 300 | 11 320 - 1 300 |
| 1 600 | 1 400 | 2 100 | | 11 310 - 1 400 | 11 320 - 1 400 |
| 1 600 | 1 500 | 2 100 | | 11 310 - 1 500 | 11 320 - 1 500 |
| 1 800 | 1 600 | 2 300 | 60 | 11 310 - 1 600 | 11 320 - 1 600 |
| 1 800 | 1 700 | 2 500 | | 11 310 - 1 700 | 11 320 - 1 700 |
| 2 000 | 1 800 | 2 500 | | 11 310 - 1 800 | 11 320 - 1 800 |

PEVNÉ NAPÍNÁNÍ STĚRAČE - MONTÁŽNÍ HODNOTY

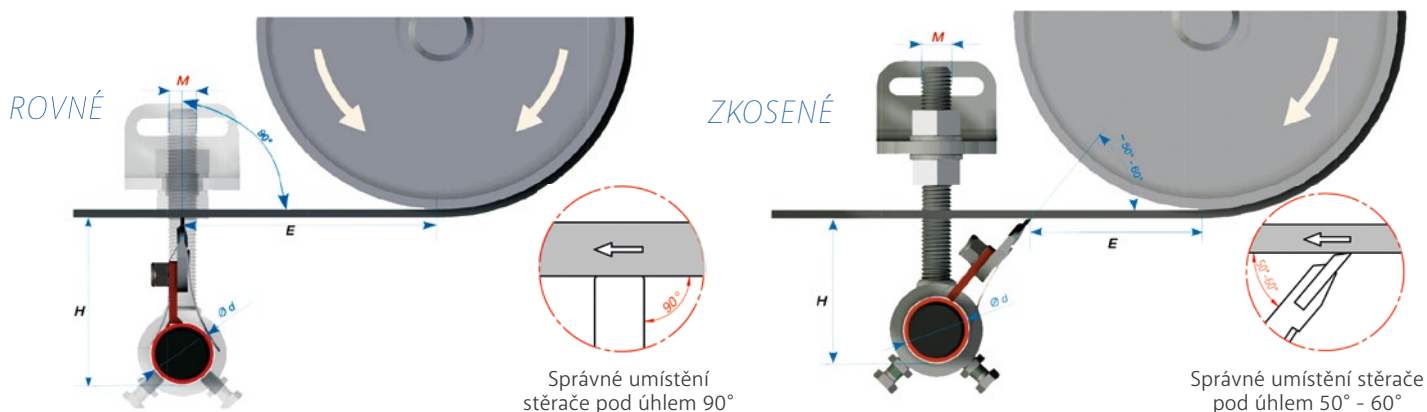

| L1 (mm) | M (mm) | H (mm) | ∅ d (mm) | E (mm) |
|-------------|-----------|-----------|-------------|------------|
| 400 - 650 | M24 x 160 | 133 | 48 | ~150 - 200 |
| 800 - 1000 | M30 x 160 | 133 | 48 | ~200 - 300 |
| 1200 - 1800 | M36 x 200 | 155 | 60 | ~300 |

| L1 (mm) | M (mm) | H (mm) | ∅ d (mm) | E (mm) |
|-------------|-----------|-----------|-------------|------------|
| 400 - 650 | M24 x 160 | 107 | 48 | ~150 - 200 |
| 800 - 1000 | M30 x 160 | 107 | 48 | ~200 - 300 |
| 1200 - 1800 | M36 x 200 | 125 | 60 | ~300 |

SPODNÍ STĚRAČ DP LT UH

— -40 °C + 80 °C

TORZNÍ NAPÍNÁNÍ STĚRAČE

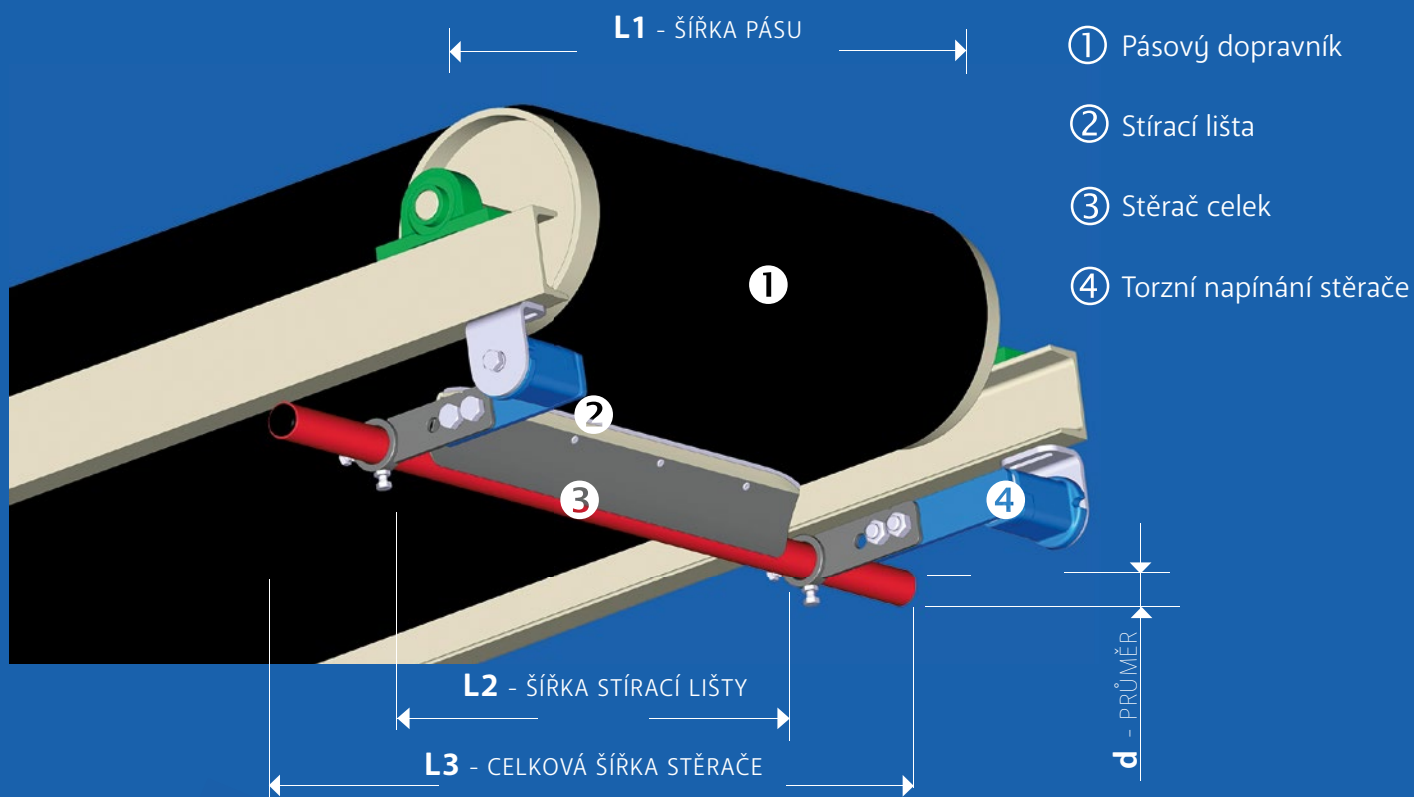

TORZNÍ NAPÍNÁNÍ - SESTAVA STĚRAČE

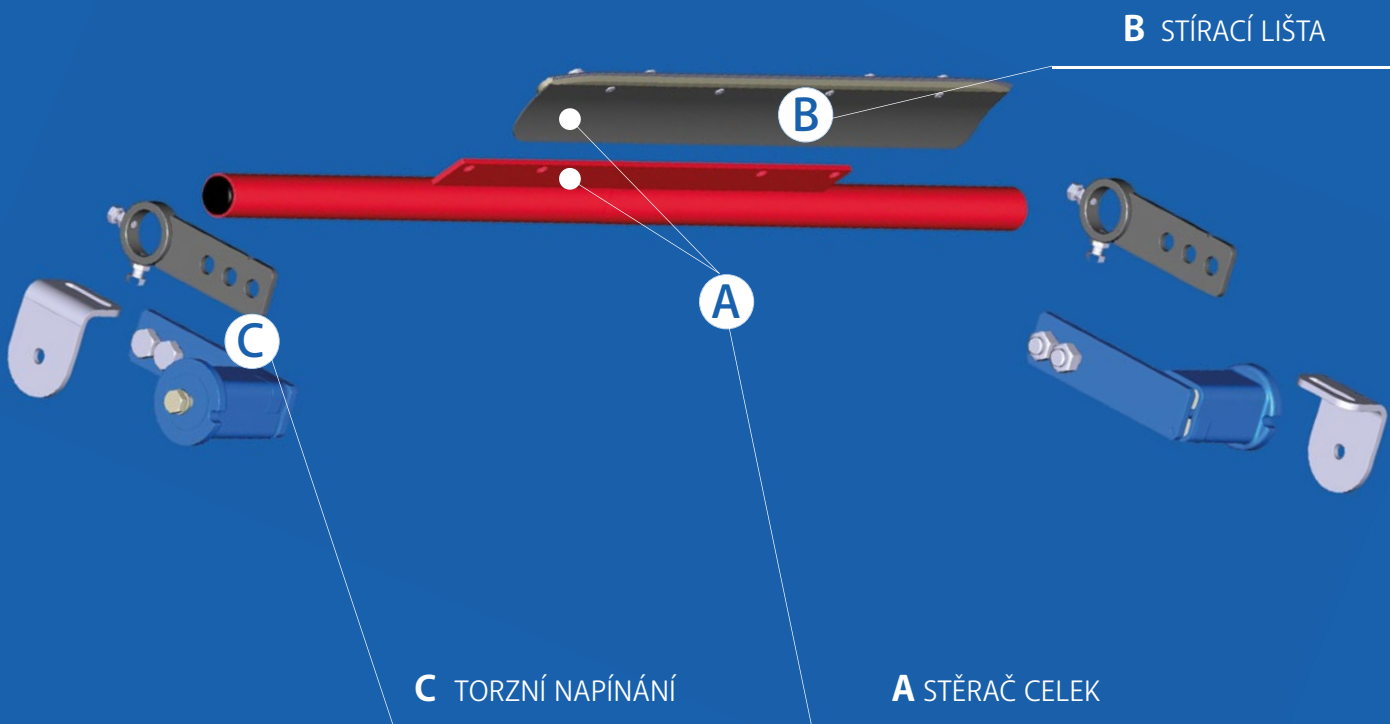

SPODNÍ STĚRAČ DP LT UH

PARAMETRY

| L1 (mm) | L2 (mm) | L3 (mm) | ø d (mm) | A | B |
|------------|------------|------------|-------------|----------------|----------------|
| 400 | 350 | 900 | 48 | 11 310 - 350 | 11 320 - 350 |
| 500 | 450 | 1 000 | | 11 310 - 450 | 11 320 - 450 |
| 650 | 550 | 1 200 | | 11 310 - 550 | 11 320 - 550 |
| 650 | 600 | 1 200 | | 11 310 - 600 | 11 320 - 600 |
| 800 | 700 | 1 300 | 48 | 11 310 - 700 | 11 320 - 700 |
| 800 | 750 | 1 300 | | 11 310 - 750 | 11 320 - 750 |
| 1 000 | 900 | 1 500 | | 11 310 - 900 | 11 320 - 900 |
| 1 000 | 950 | 1 500 | | 11 310 - 950 | 11 320 - 950 |
| 1 200 | 1 050 | 1 700 | 60 | 11 310 - 1 050 | 11 320 - 1 050 |
| 1 200 | 1 125 | 1 700 | | 11 310 - 1 125 | 11 320 - 1 125 |
| 1 400 | 1 200 | 1 900 | | 11 310 - 1 200 | 11 320 - 1 200 |
| 1 400 | 1 300 | 1 900 | | 11 310 - 1 300 | 11 320 - 1 300 |
| 1 600 | 1 400 | 2 100 | | 11 310 - 1 400 | 11 320 - 1 400 |
| 1 600 | 1 500 | 2 100 | | 11 310 - 1 500 | 11 320 - 1 500 |

TORZNÍ NAPÍNÁNÍ STĚRAČE - MONTÁŽNÍ HODNOTY

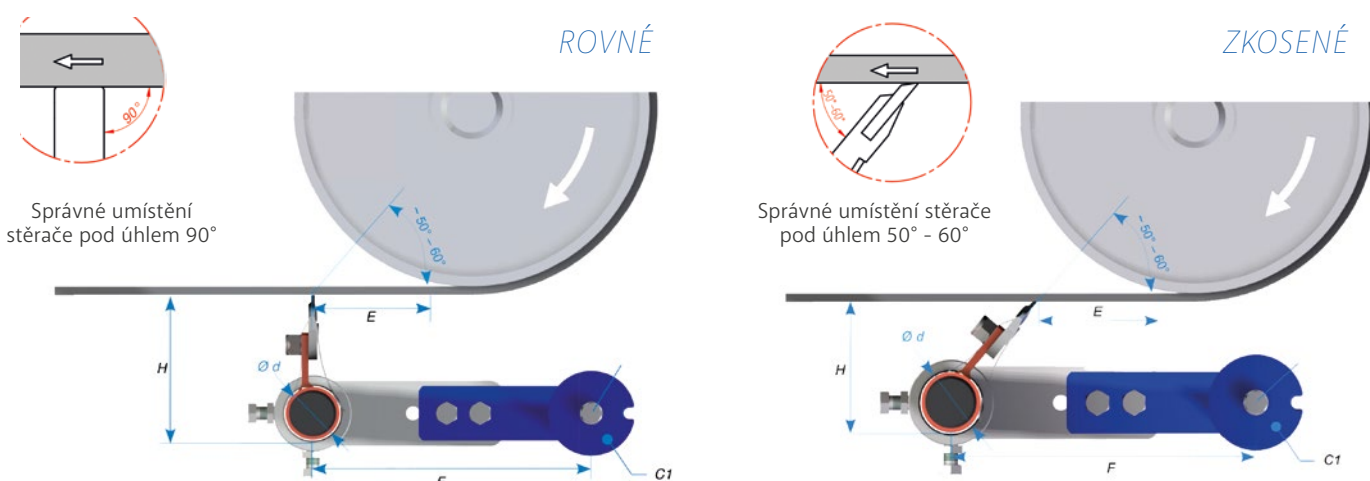

| L1 (mm) | C1 (mm) | H (mm) | ø d (mm) | E (mm) | F (mm) |
|-------------|------------|-----------|-------------|-----------|-----------|
| 400 - 650 | M12 | 133 | 48 | 100-200 | 250 |
| 800 - 1000 | M16 | 133 | 48 | 100-200 | 303 |
| 1200 - 1400 | M16 | 155 | 60 | 150-300 | 340 |
| 1600 | M20 | 155 | 60 | 150-300 | 340 |

| L1 (mm) | C1 (mm) | H (mm) | ø d (mm) | E (mm) | F (mm) |
|-------------|------------|-----------|-------------|-----------|-----------|
| 400 - 650 | M12 | 107 | 48 | 100-200 | 250 |
| 800 - 1000 | M16 | 107 | 48 | 100-200 | 303 |
| 1200 - 1400 | M16 | 125 | 60 | 150-300 | 340 |
| 1600 | M20 | 125 | 60 | 150-300 | 340 |

SPODNÍ STĚRAČ DP R2.0 UH

−40 °C +150 °C

PEVNÉ NAPÍNÁNÍ STĚRAČE

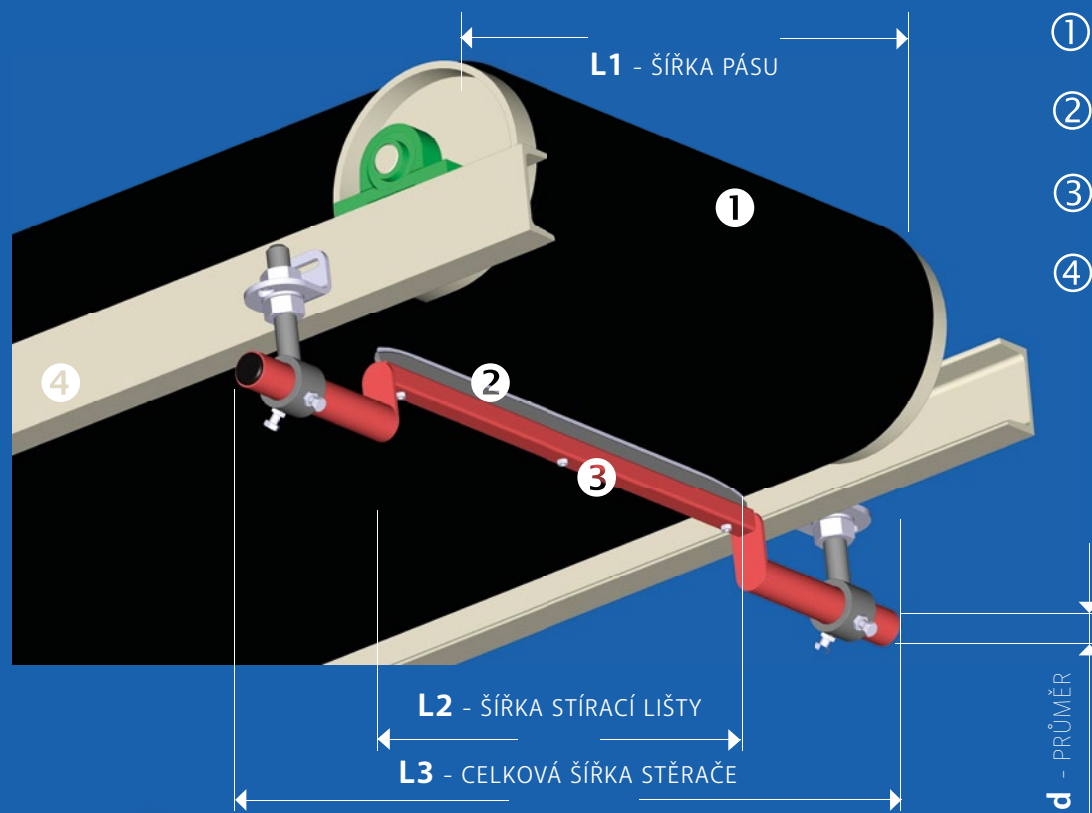

PEVNÉ NAPÍNÁNÍ - SESTAVA STĚRAČE

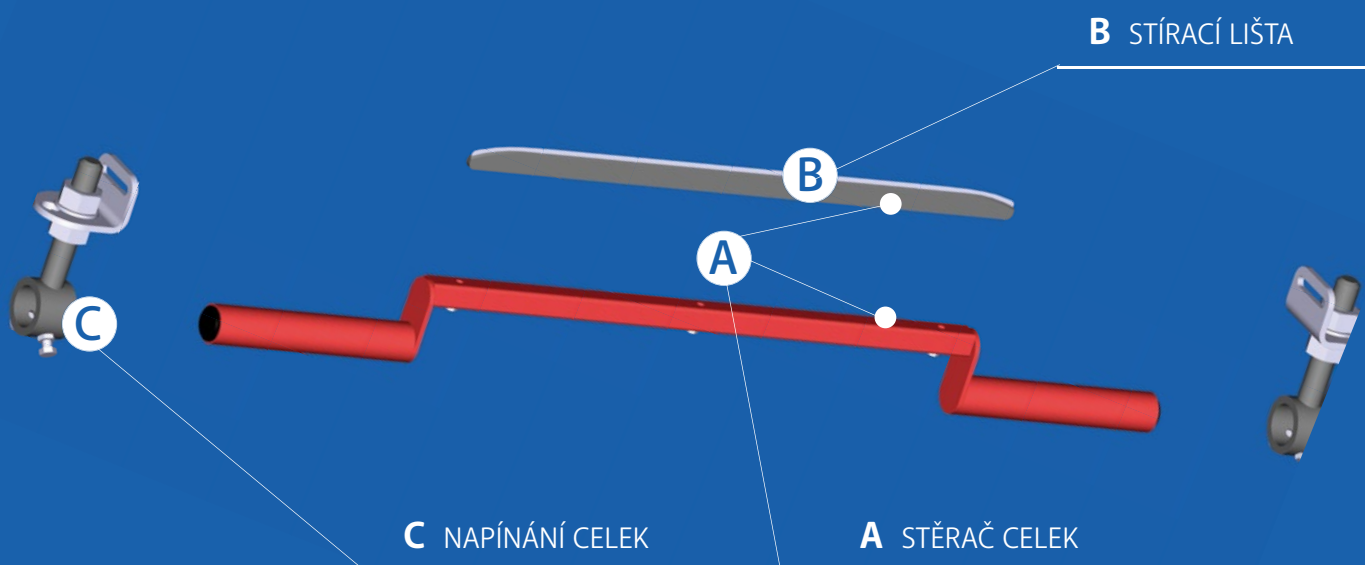

SPODNÍ STĚRAČ DP R2.0 UH

PARAMETRY

| L1 (mm) | L2 (mm) | L3 (mm) | ø d (mm) | A | B |
|------------|------------|------------|-------------|----------------|----------------|
| 400 | 350 | 900 | 48 | 11 420 - 350 | 11 320 - 350 |
| 500 | 450 | 1 000 | | 11 420 - 450 | 11 320 - 450 |
| 650 | 600 | 1 200 | | 11 420 - 600 | 11 320 - 550 |
| 800 | 750 | 1 300 | 48 | 11 420 - 750 | 11 320 - 700 |
| 1 000 | 950 | 1 500 | | 11 420 - 950 | 11 320 - 750 |
| 1 200 | 1 125 | 1 700 | 60 | 11 420 - 1 125 | 11 320 - 1 050 |
| 1 400 | 1 300 | 1 900 | | 11 420 - 1 300 | 11 320 - 1 125 |

NAPÍNÁNÍ STĚRAČE - MONTÁŽNÍ HODNOTY

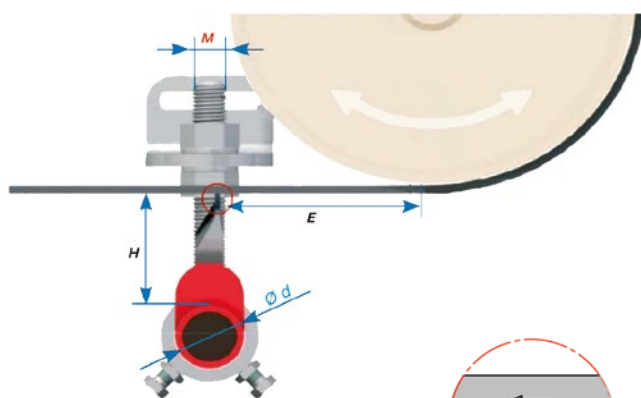

Správné umístění
stěrače pod úhlem 90°

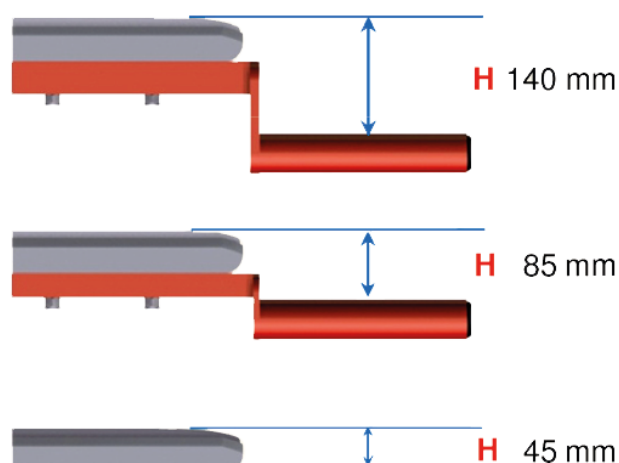

| L1 (mm) | M (mm) | ø d (mm) | E (mm) |
|---------------|-----------|-------------|------------|
| 400 - 650 | M24 x 160 | 48 | ~150 - 200 |
| 800 - 1 000 | M30 x 160 | 48 | ~200 - 300 |
| 1 200 - 1 400 | M36 x 200 | 60 | ~ 300 |

SPODNÍ STĚRAČ DP PU 90

−30 °C +80 °C

PRUŽNÉ ULOŽENÍ STĚRAČE

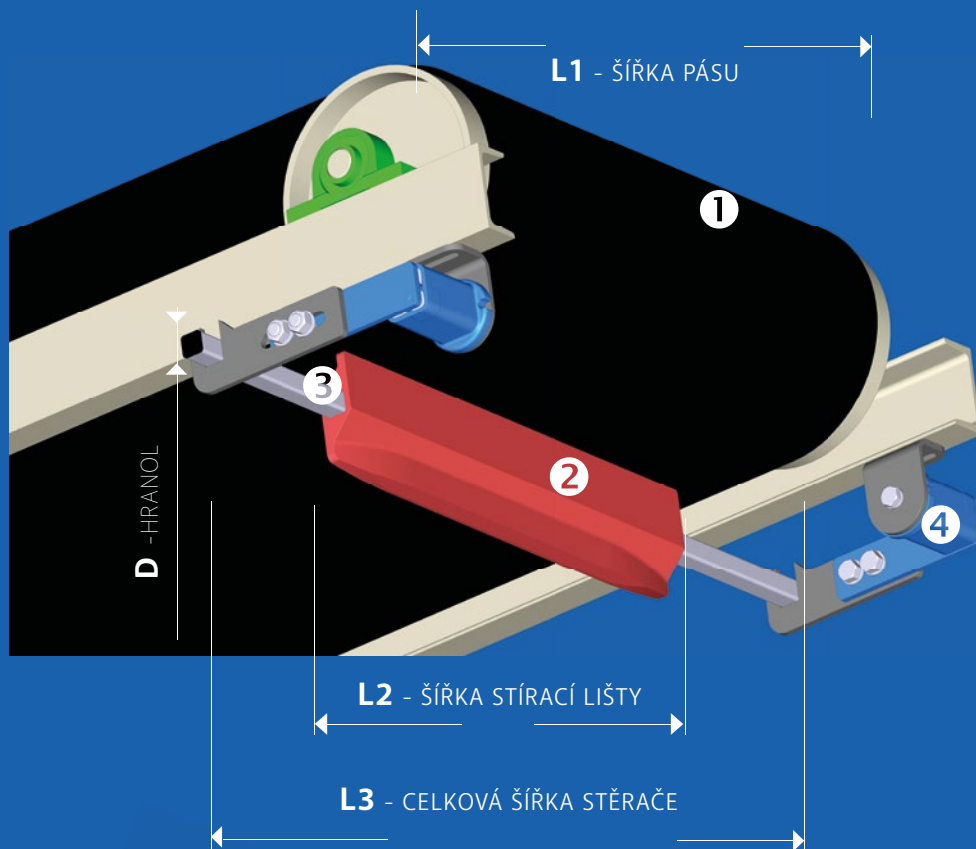

- ① Pásový dopravník
- ② Stírací lišta PU
- ③ Stěrač celek
- ④ Napínání stěrače

TORZNÍ NAPÍNÁNÍ - SESTAVA STĚRAČE

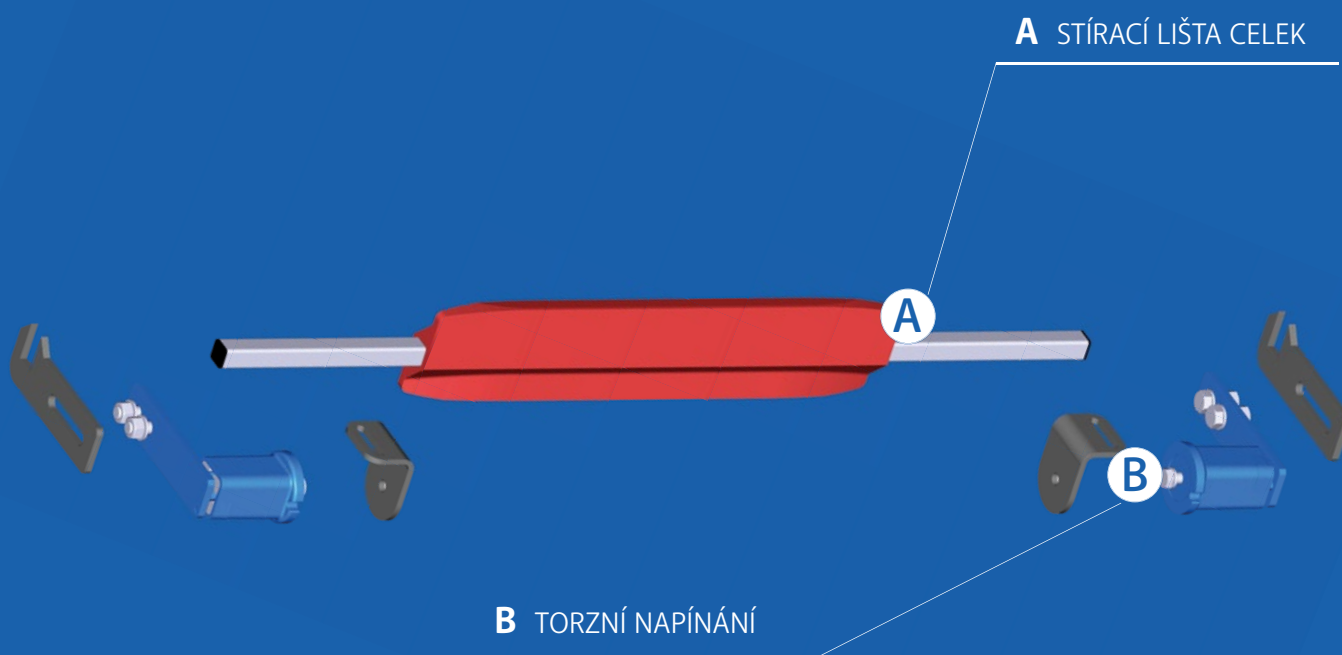

SPODNÍ STĚRAČ DP PU 90

PARAMETRY

| L1 (mm) | L2 (mm) | L3 (mm) | D (mm) | A |
|------------|------------|------------|-------------|----------------|
| 400 | 350 | 850 | 30 x 30 x 3 | 11 010 - 350 |
| 500 | 450 | 1 000 | | 11 010 - 450 |
| 650 | 600 | 1 200 | | 11 010 - 600 |
| 800 | 700 | 1 200 | | 11 010 - 700 |
| 800 | 800 | 1 300 | | 11 010 - 800 |
| 1 000 | 900 | 1 500 | 30 x 30 x 4 | 11 010 - 900 |
| 1 000 | 1 000 | 1 500 | | 11 010 - 1 000 |
| 1 200 | 1 100 | 1 500 | | 11 010 - 1 100 |
| 1 400 | 1 200 | 1 500 | | 11 010 - 1 200 |
| 1 400 | 1 300 | 1 500 | | 11 010 - 1 300 |

NAPÍNÁNÍ STĚRAČE - MONTÁŽNÍ HODNOTY

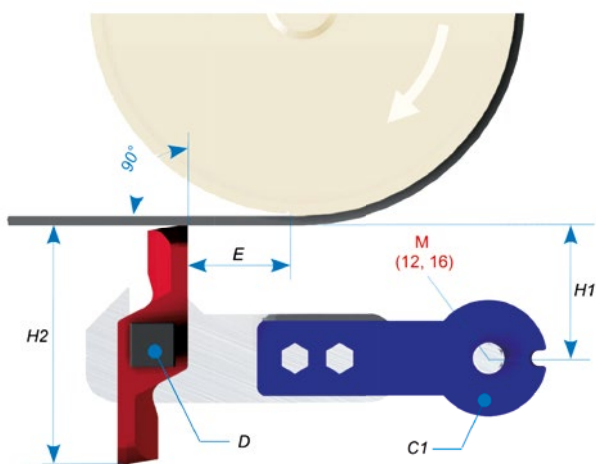

| L1 (mm) | C1 (mm) | D (mm) | H1 (mm) | H2 (mm) | E (mm) |
|---------------|------------|-------------|------------|------------|-----------|
| 400 - 800 | M12 | 30 x 30 x 3 | ~90 | 160 | ~50 - 100 |
| 1 000 - 1 400 | M16 | 30 x 30 x 4 | ~90 | 160 | ~50 - 100 |

ČELNÍ STĚRAČ DP PU 90

−30 °C +80 °C

PRUŽINOVÉ ULOŽENÍ STĚRAČE

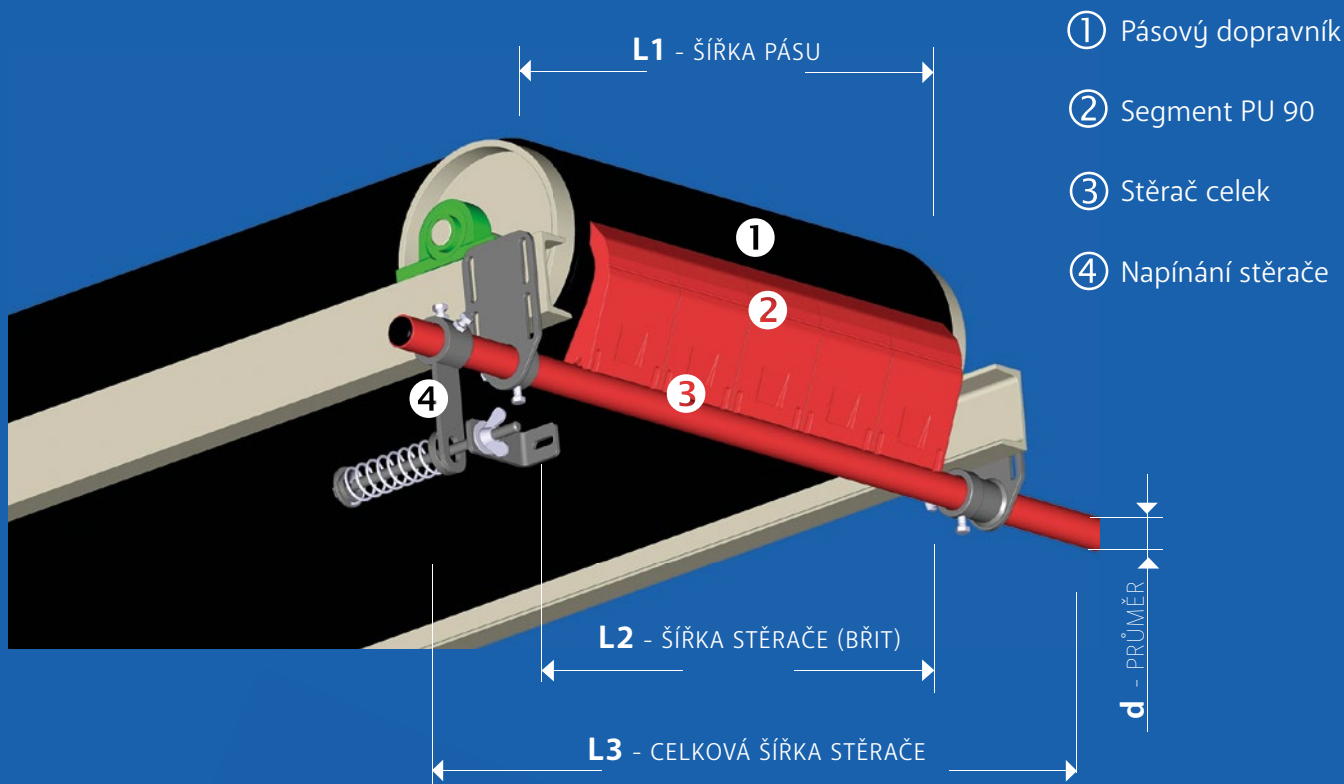

SESTAVA STĚRAČE

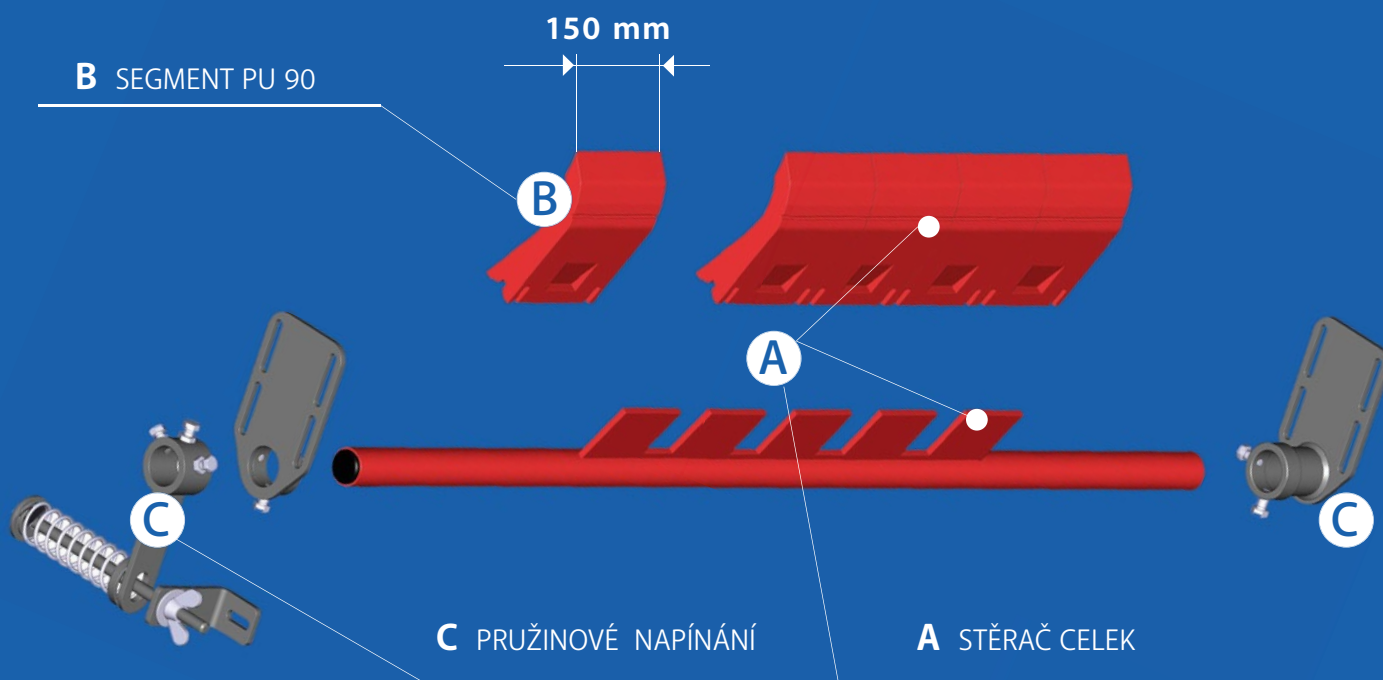

ČELNÍ STĚRAČ DP PU 90

 v max ~ 4m/s

PARAMETRY

| L1 (mm) | L2 (mm) | L3 (mm) | B segmenty | ø d (mm) | A | B |
|------------|------------|------------|---------------|-------------|---------------|--------------|
| 500 | 300 | 1000 | 2 | 48 | 12 110 - 300 | 12 120 - 150 |
| 650 | 450 | 1200 | 3 | | 12 110 - 450 | |
| 800 | 600 | 1300 | 4 | | 12 110 - 600 | |
| 1000 | 750 | 1500 | 5 | | 12 110 - 750 | |
| 1200 | 900 | 1700 | 6 | 60 | 12 110 - 900 | |
| 1400 | 1050 | 1900 | 7 | | 12 110 - 1050 | |
| 1600 | 1200 | 2100 | 8 | | 12 110 - 1200 | |
| 1600 | 1350 | 2100 | 9 | | 12 110 - 1350 | |

VARIANTY SEGMENTŮ

ATEX

FDA

VO

-30 °C - 150 °C



Antistatický

Potravinářská
kvalita

Samozhášivý

Tepelně odolný

L1: 500 mm - 1000mm - d=48mm

L1: 1200 mm - 1600mm - d=60mm

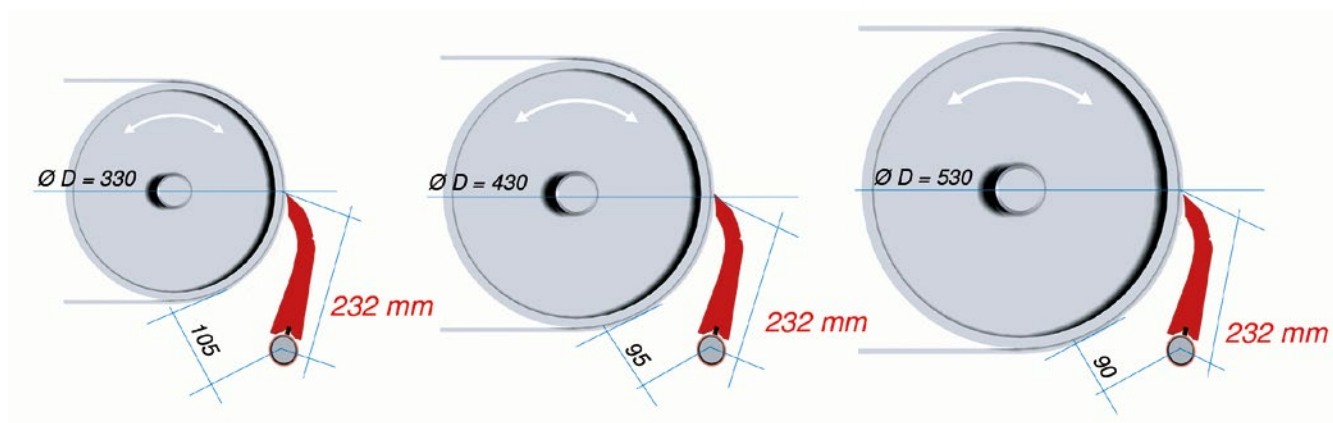

ČELNÍ STĚRAČ DP PU 90 S

−30 °C +80 °C

ULOŽENÍ STĚRAČE

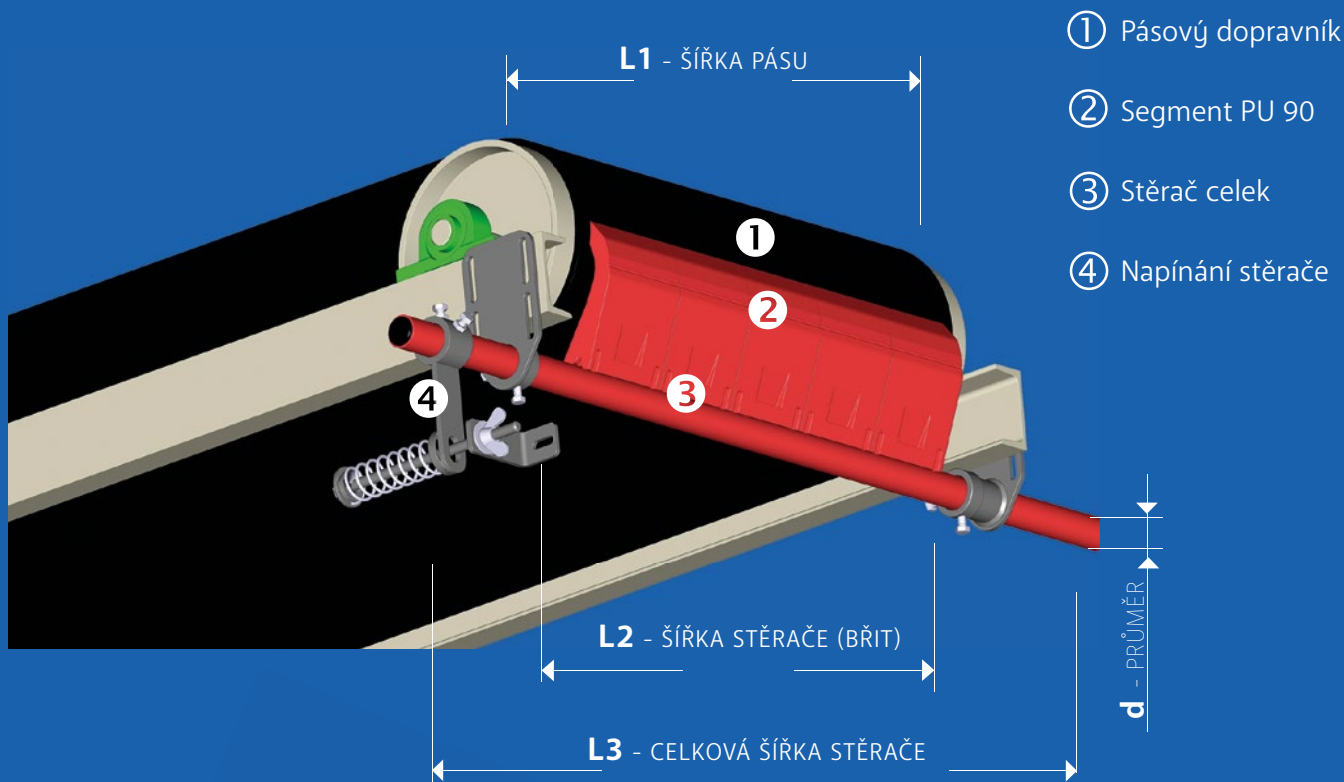

SESTAVA STĚRAČE

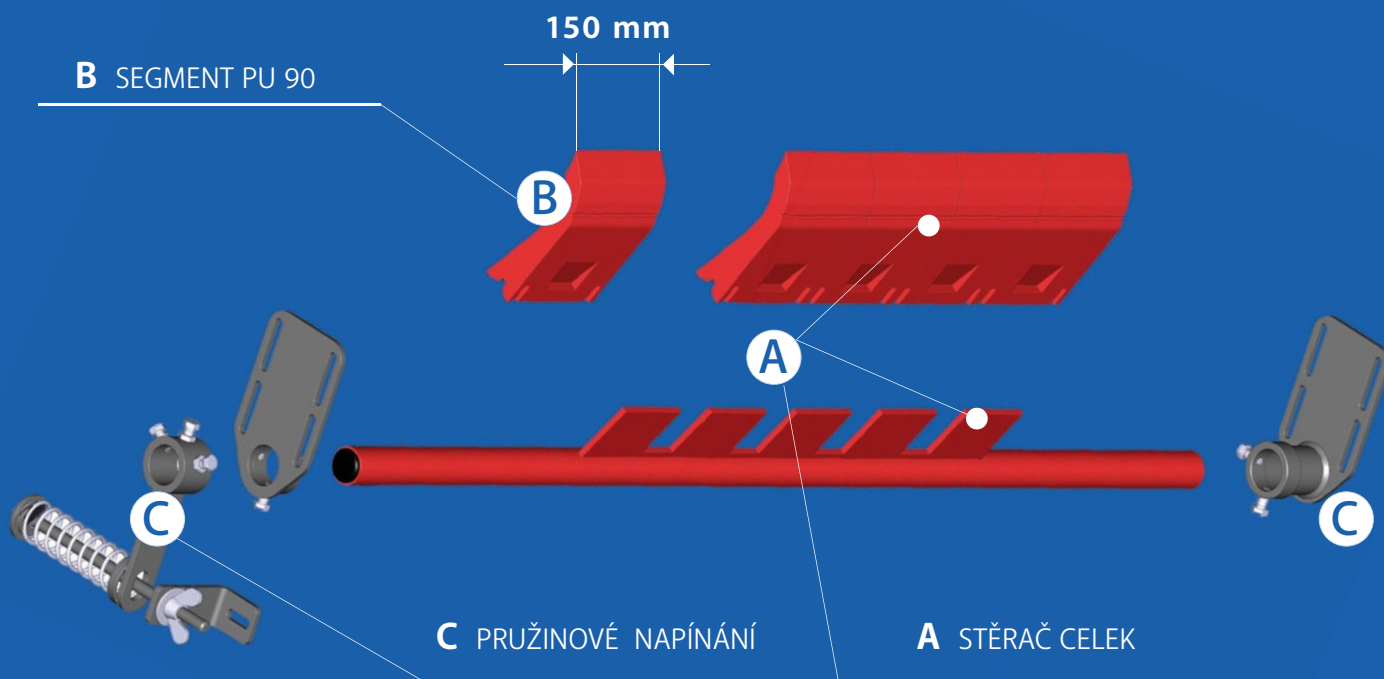

ČELNÍ STĚRAČ DP PU 90 S

 v max ~ 4m/s

PARAMETRY

| L1 (mm) | L2 (mm) | L3 (mm) | B segmenty | ø d (mm) | A | B |
|------------|------------|------------|---------------|-------------|------------------|----------|
| 500 | 300 | 1 000 | 2 | 48 | 12 110 - 300 S | 12 120 S |
| 650 | 450 | 1 200 | 3 | | 12 110 - 450 S | |
| 800 | 600 | 1 300 | 4 | | 12 110 - 600 S | |
| 1 000 | 750 | 1 500 | 5 | | 12 110 - 750 S | |
| 1 200 | 900 | 1 700 | 6 | 60 | 12 110 - 900 S | |
| 1 200 *) | 1 050 | 1 700 | 7 | | 12 110 - 1 050 S | |

TECHNICKÉ DETAILY A MONTÁŽNÍ HODNOTY

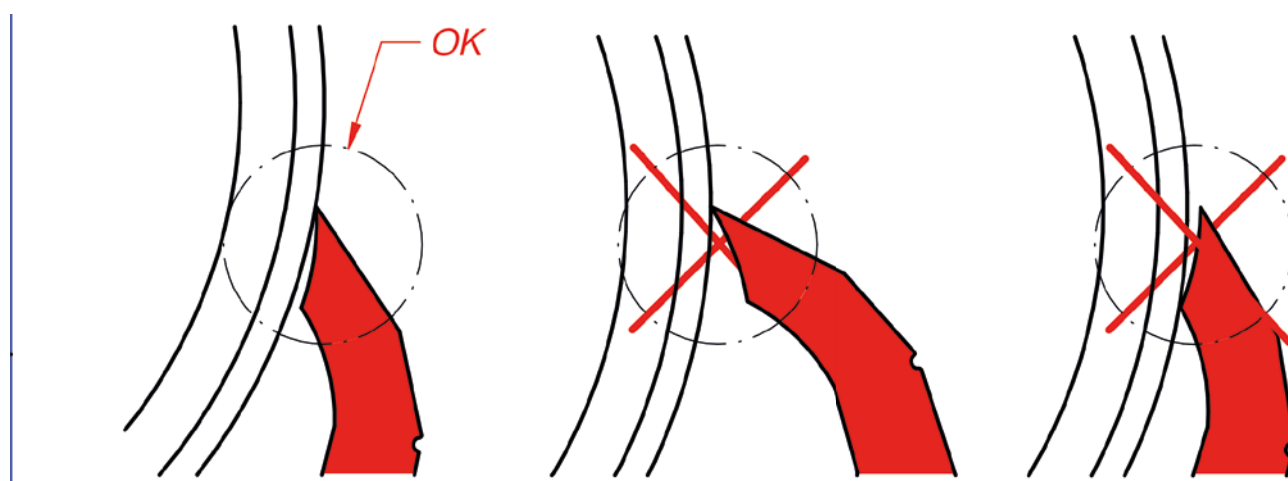

L1: 300 mm - 1 000 mm - d=48 mm

L1: 1 200 mm - d=60 mm

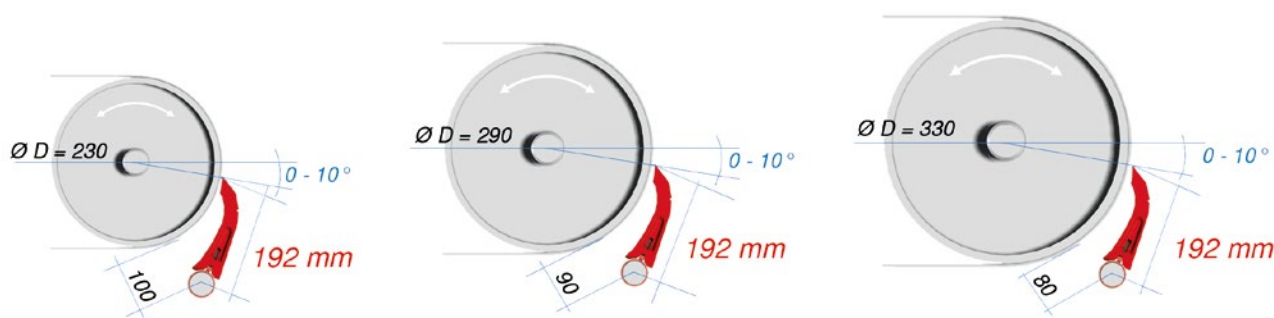

ČELNÍ STĚRAČ DP PU 90 L

−30 °C +80 °C

PRUŽINOVÉ ULOŽENÍ STĚRAČE

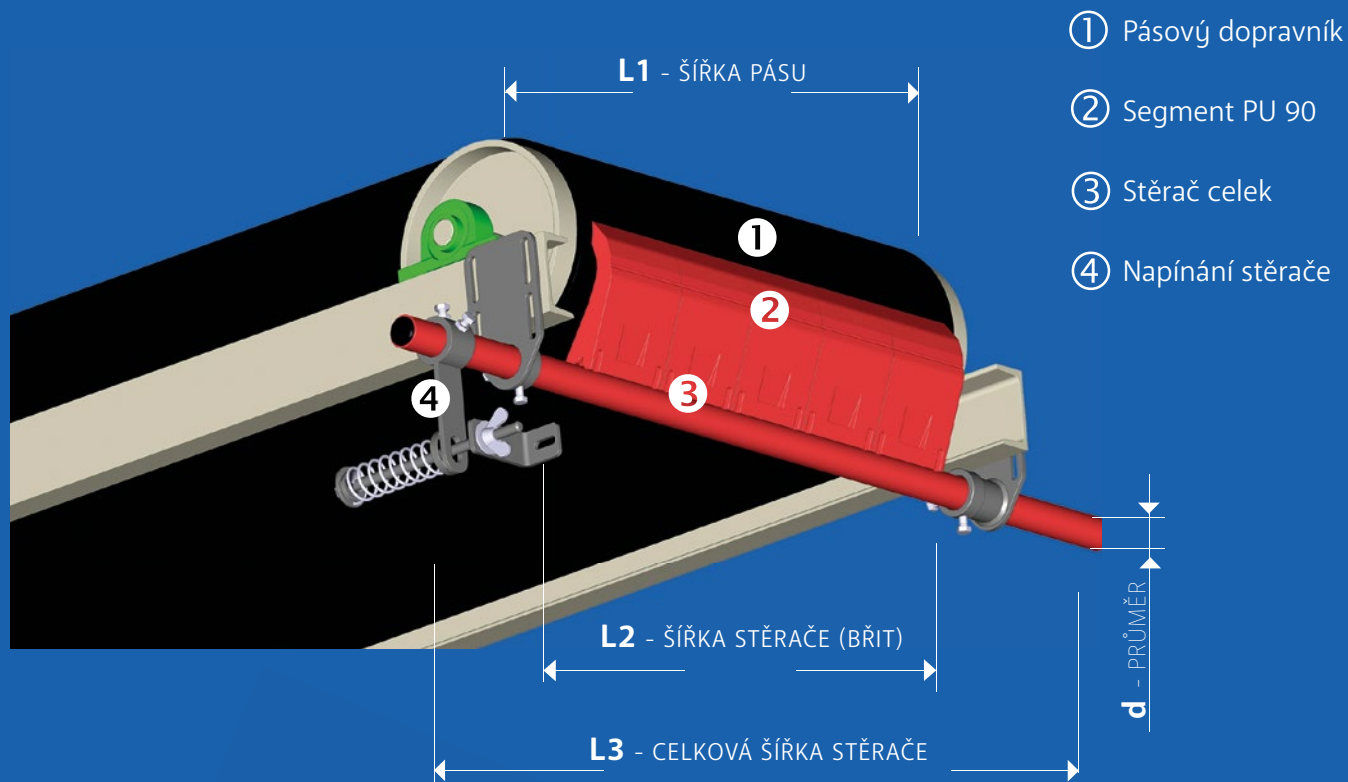

SESTAVA STĚRAČE

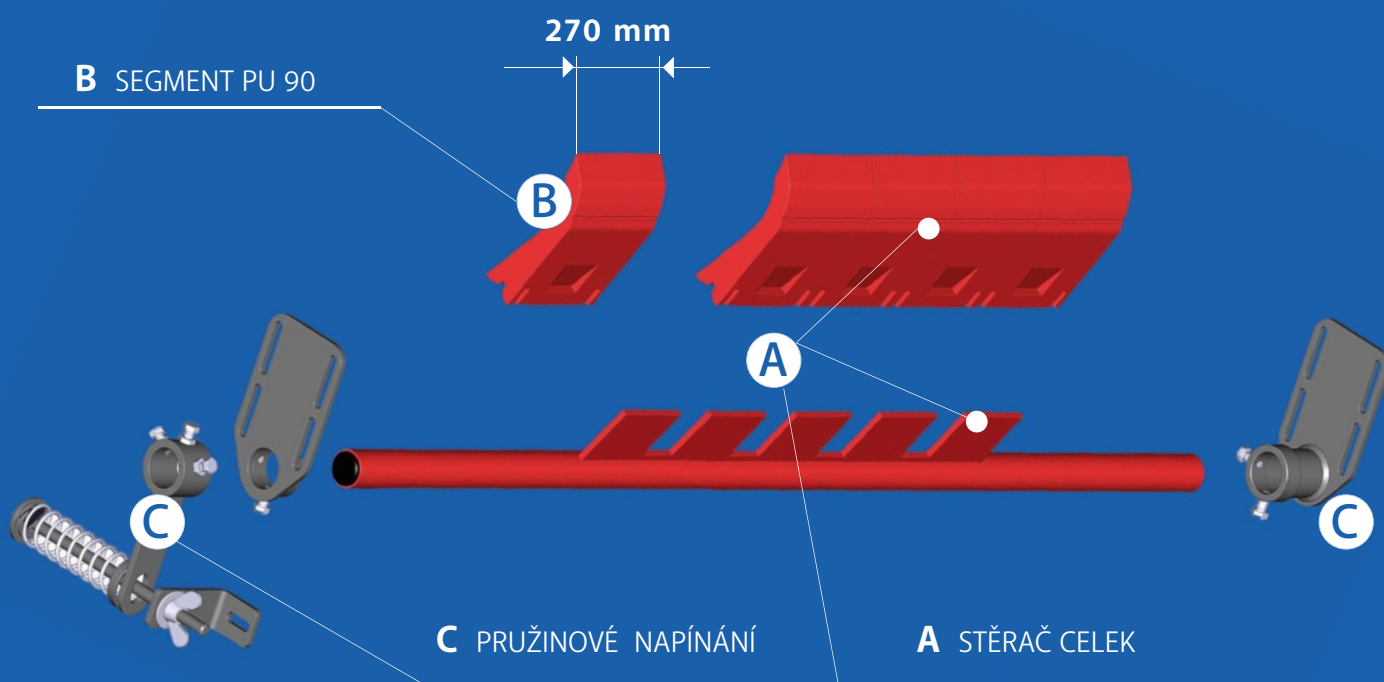

ČELNÍ STĚRAČ DP PU 90 L

 v max ~ 5 -6 m/s

PARAMETRY

| L1 (mm) | L2 (mm) | L3 (mm) | B segmenty | ø d (mm) | A | B |
|---------------|------------|------------|---------------|-------------|------------------|----------|
| 800 | 540 | 1300 | 2 | 76 | 12 110 - 540 L | 12 120 L |
| 1 000 | 810 | 1500 | 3 | | 12 110 - 810 L | |
| 1 200 - 1 400 | 1 080 | 1 900 | 4 | | 12 110 - 1 080 L | |
| 1 600 | 1 350 | 2 100 | 5 | | 12 110 - 1 350 L | |
| 1 800 | 1 620 | 2 300 | 6 | | 12 110 - 1 620 L | |
| 2 000 - 2 200 | 1 890 | 2 700 | 7 | | 12 110 - 2 890 L | |
| 2 400 | 2 160 | 2 900 | 8 | | 12 110 - 2 160 L | |

TECHNICKÉ DETAILY A MONTÁŽNÍ HODNOTY

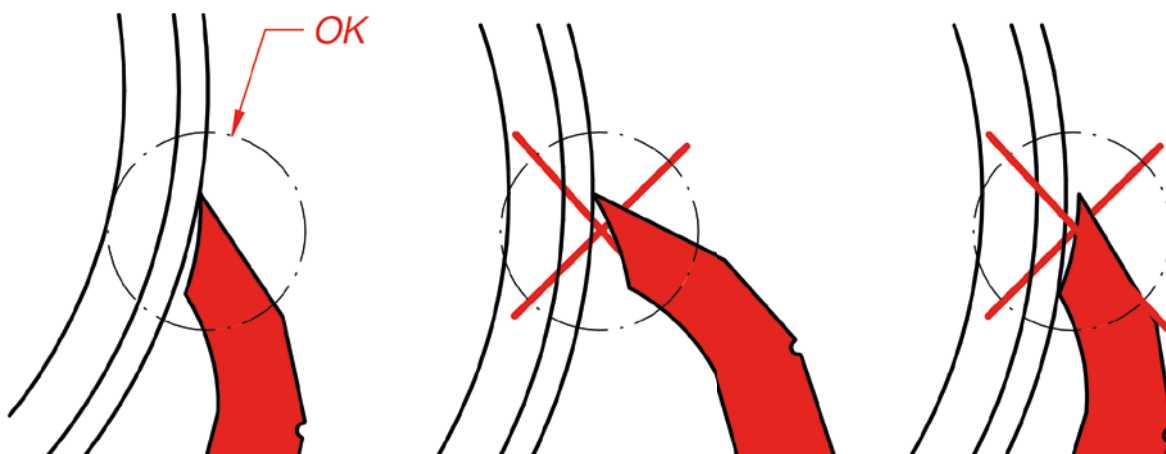

L1: 800 mm - 2400mm - d=76mm

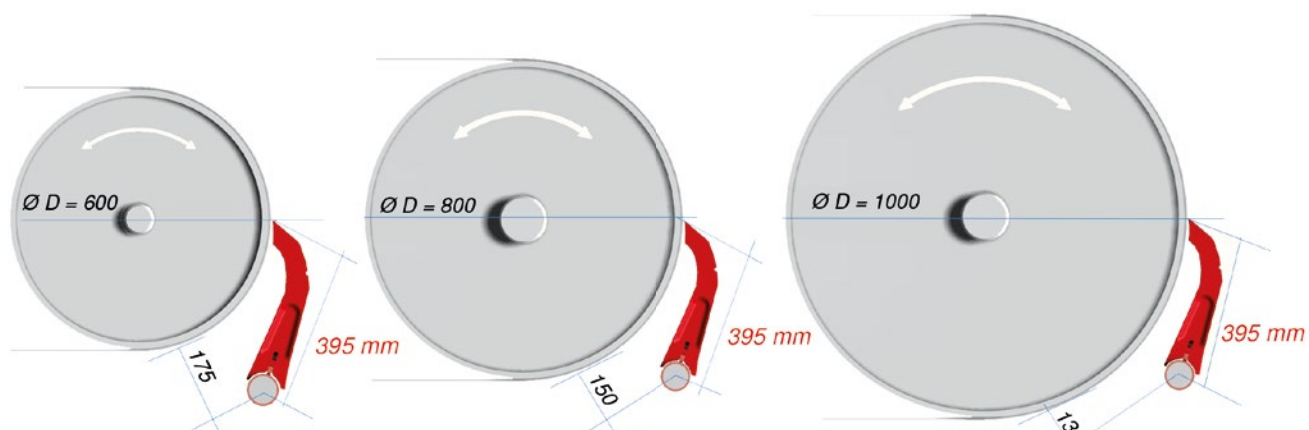

ČELNÍ STĚRAČ DP UH2

−30 °C +80 °C

PRUŽINOVÉ ULOŽENÍ STĚRAČE

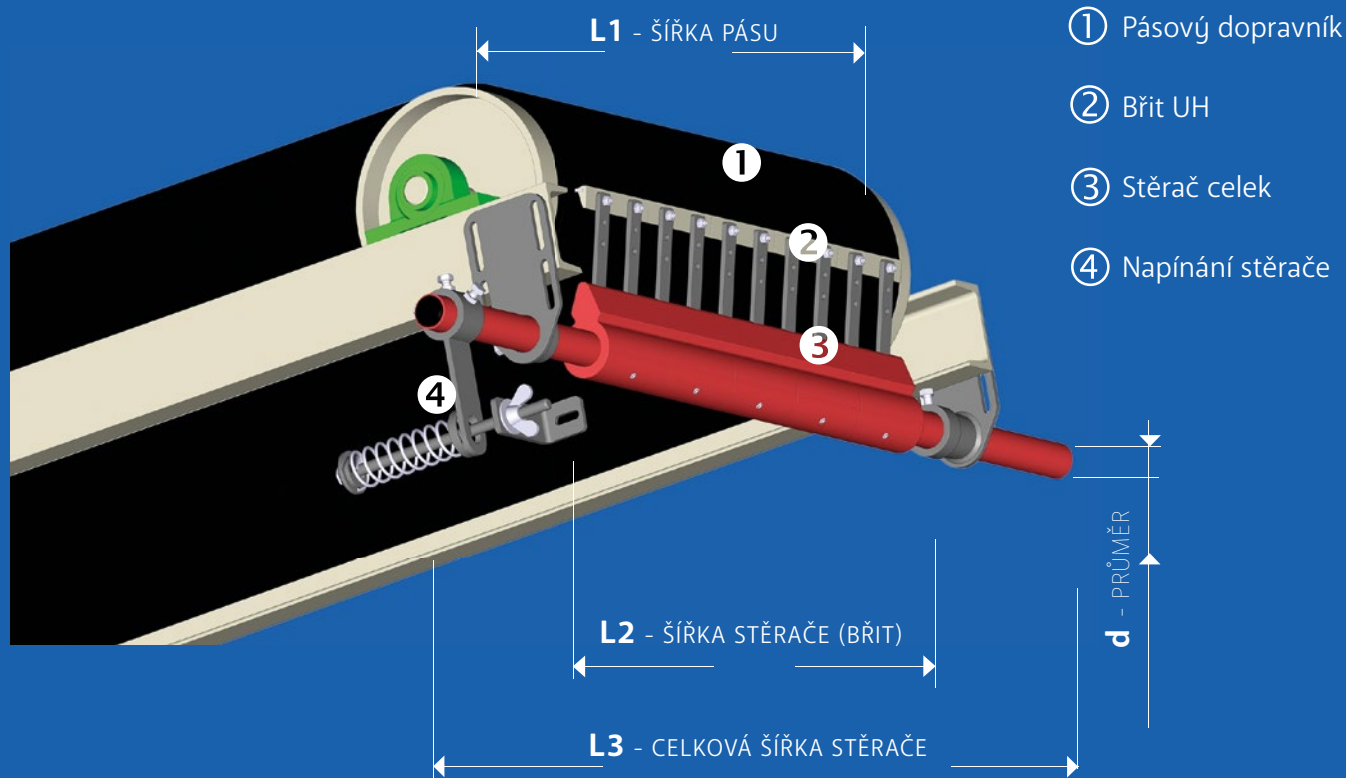

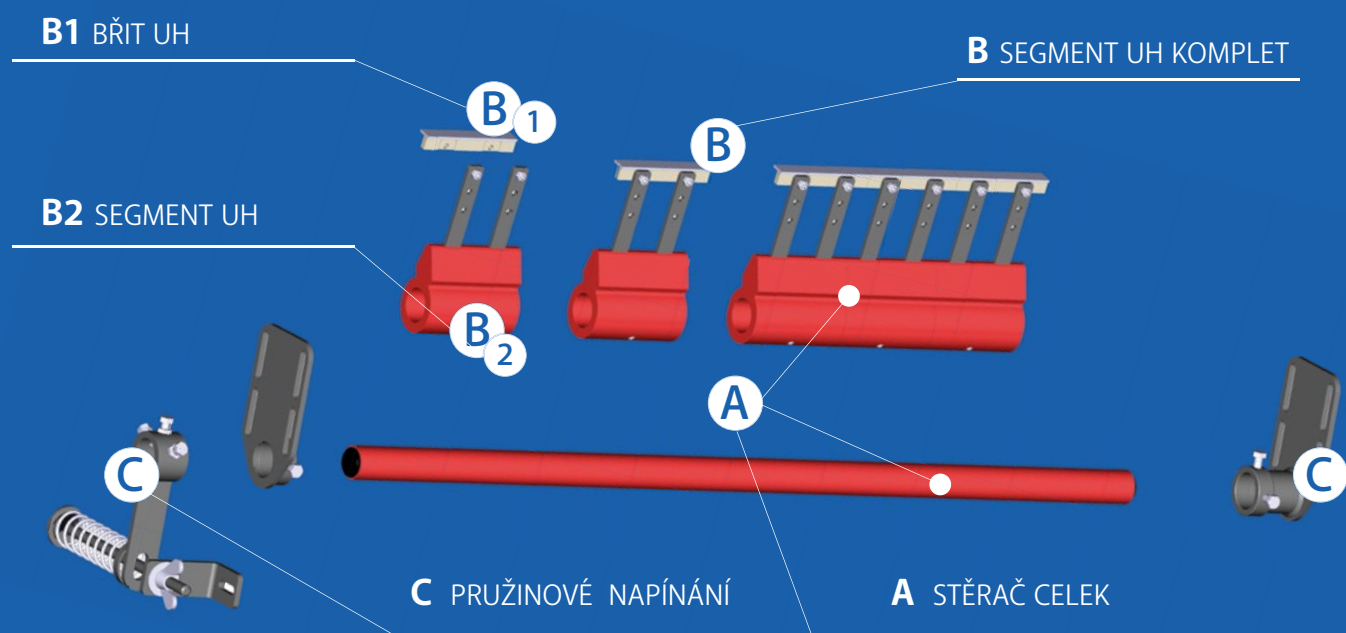

PRUŽINOVÉ ULOŽENÍ STĚRAČE



ČELNÍ STĚRAČ DP UH2

 v max 1,5 m/s

PARAMETRY

| UH 1.0 | L1 (mm) | L2 (mm) | L3 (mm) | B počet | ø d (mm) | A | B | B ₁ | B ₂ |
|---|------------|------------|------------|------------|-------------|------------------|-----------------|-----------------|----------------|
|  | 500 | 300 | 1000 | 2 | 48 | 11 610 – 300 | 11 610 – 150 | 11 620 – 150 | 11 611 |
| | 650 | 450 | 1200 | 4 | | 11 610 – 450 | | | |
| | 800 | 600 | 1300 | 5 | | 11 610 – 600 | | | |
| | 1000 | 750 | 1500 | 6 | | 11 610 – 750 | | | |
| | 1200 | 900 | 1700 | 6 | | 11 610 – 900 | | | |
| | 1400 | 1280 | 1900 | 8 | | 11 610 – 1200 | | | |
| UH 2.0 | L1 (mm) | L2 (mm) | L3 (mm) | B počet | ø d (mm) | A | B | B ₁ | B ₂ |
|  | 500 | 300 | 1000 | 2 | 48 | 11 610 – 300 HD | 11 610 – 150 HD | 11 620 – 150 HD | 11 611 |
| | 650 | 450 | 1200 | 4 | | 11 610 – 450 HD | | | |
| | 800 | 600 | 1300 | 5 | | 11 610 – 600 HD | | | |
| | 1000 | 750 | 1500 | 6 | | 11 610 – 750 HD | | | |
| | 1200 | 900 | 1700 | 6 | | 11 610 – 900 HD | | | |
| | 1400 | 1280 | 1900 | 8 | | 11 610 – 1200 HD | | | |

NAPÍNÁNÍ STĚRAČE - MONTÁŽNÍ HODNOTY

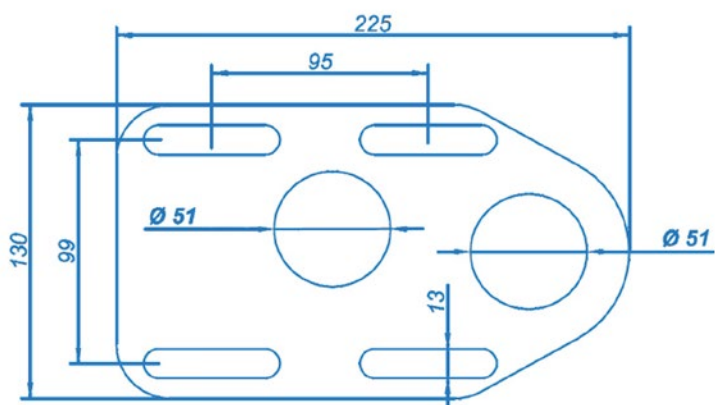
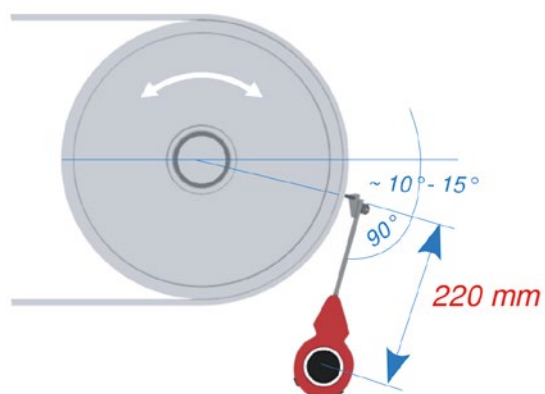

ČELNÍ STĚRAČ DP UH3

−30 °C +80 °C

PRUŽINOVÉ ULOŽENÍ STĚRAČE

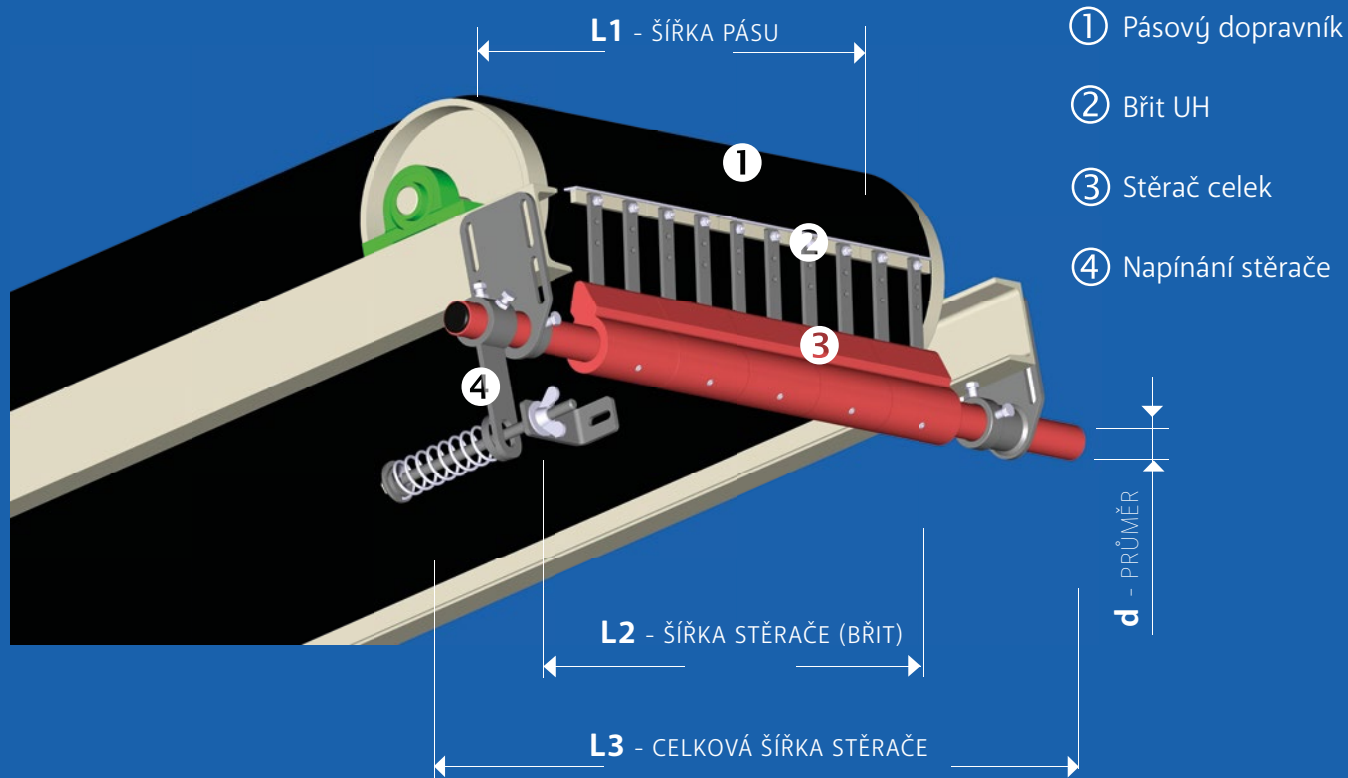

PRUŽINOVÉ ULOŽENÍ STĚRAČE

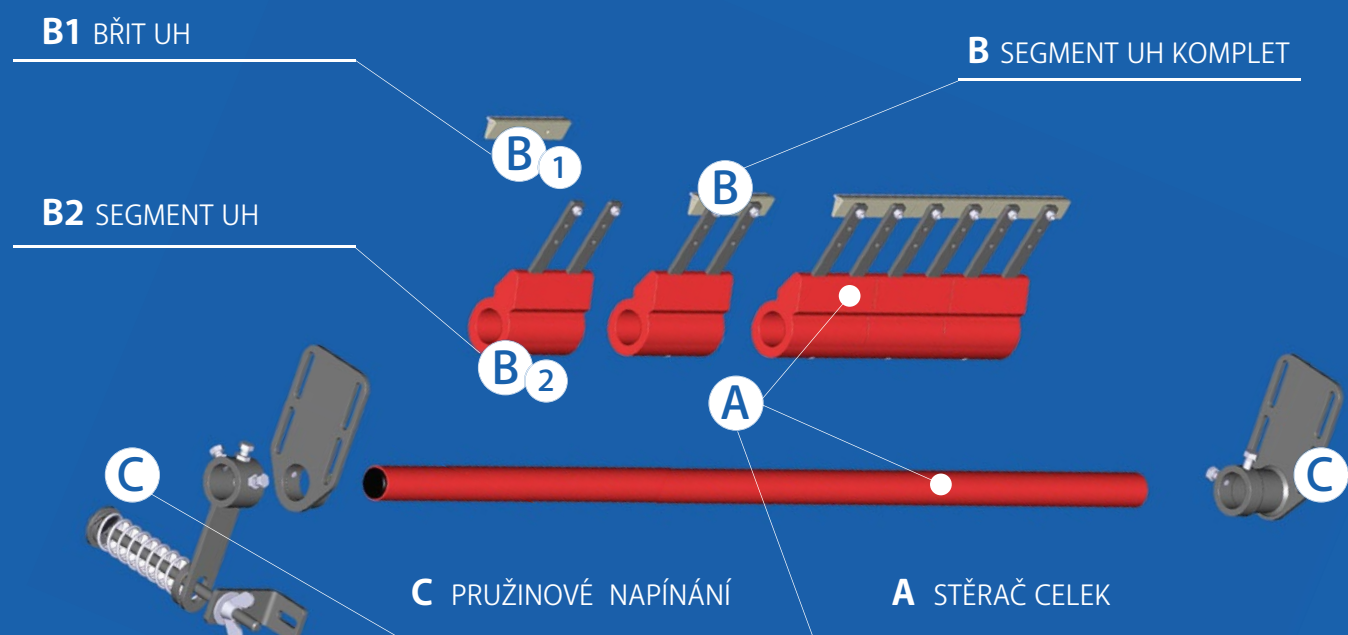

ČELNÍ STĚRAČ DP UH3

 v max 1,5 m/s

NAPÍNÁNÍ STĚRAČE - PARAMETRY

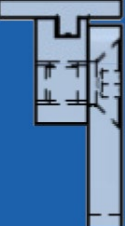
| UH 3.0 | L1 (mm) | L2 (mm) | L3 (mm) | B segmenty | ø d (mm) | A | B | B ₁ |
|--|------------|------------|------------|---------------|-------------|-------------|-------|----------------|
|  | 650 | 450 | 1200 | 3 | 60 | 11710 – 450 | 11710 | 11720 – 150 HD |
| | 800 | 600 | 1300 | 4 | | 1710 – 600 | | |
| | 1000 | 750 | 1500 | 5 | | 1710 – 750 | | |
| | 1200 | 900 | 1700 | 6 | | 1710 – 900 | | |
| | 1400 | 1200 | 1900 | 68 | | 1710 – 1200 | | |
| | 1600 | 1350 | 2100 | 9 | | 1710 – 1350 | | |
| | 1800 | 1500 | 2300 | 10 | | 1710 – 1500 | | |
| | 2000 | 1800 | 2500 | 12 | | 1710 – 1800 | | |

NAPÍNÁNÍ STĚRAČE - MONTÁŽNÍ HODNOTY

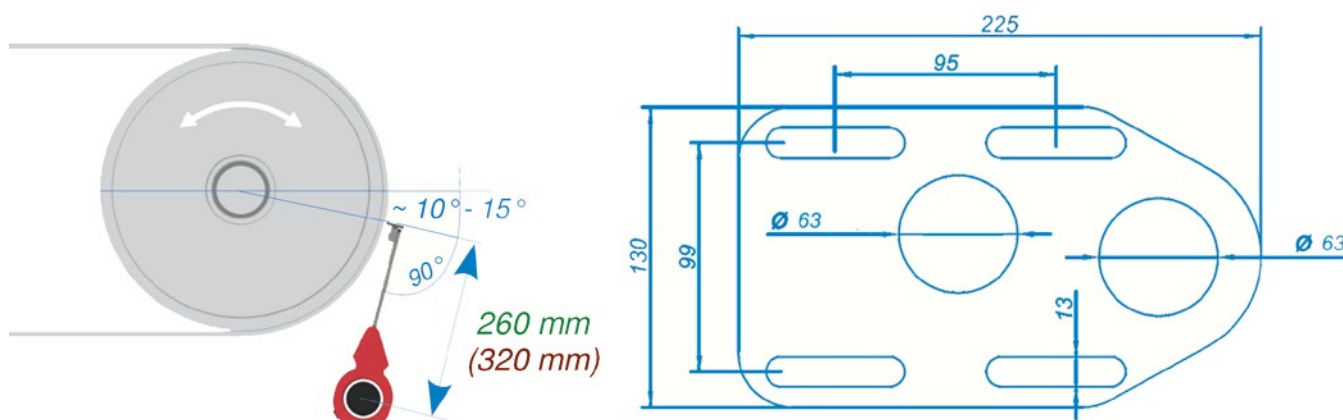

SPODNÍ STĚRAČ DP PROFIL

−30 °C +80 °C

PEVNÉ ULOŽENÍ STĚRAČE

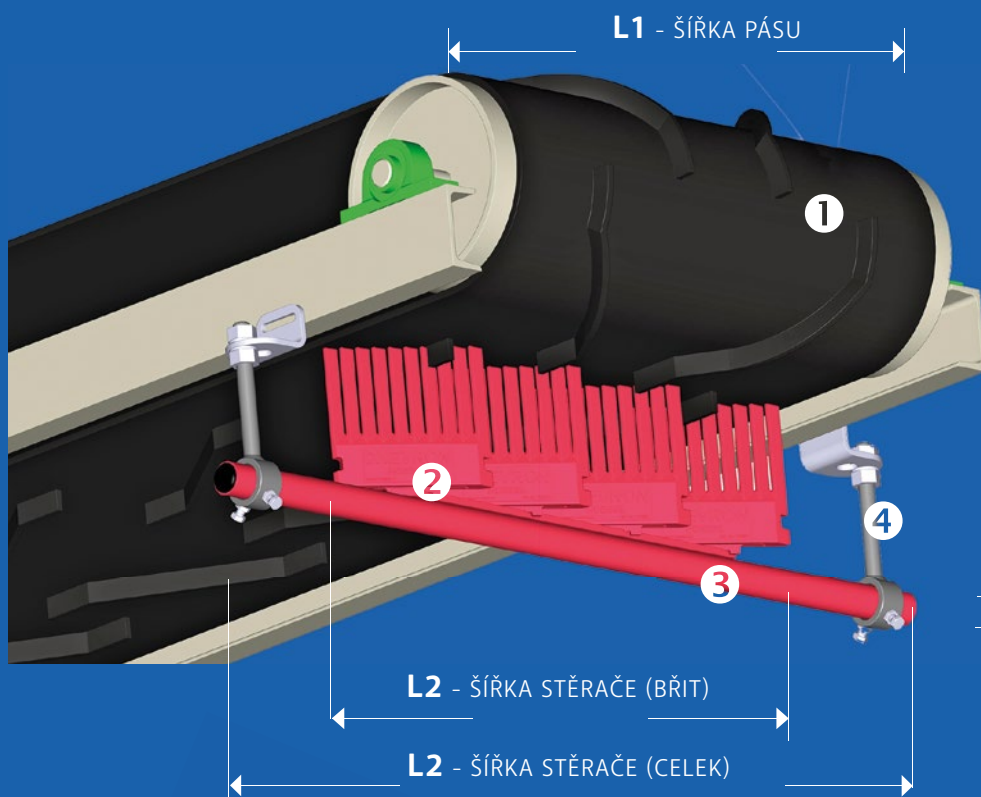

- ① Pásový dopravník
- ② Segment Profil
- ③ Stěrač celek
- ④ Napínání stěrače

SESTAVA STĚRAČE

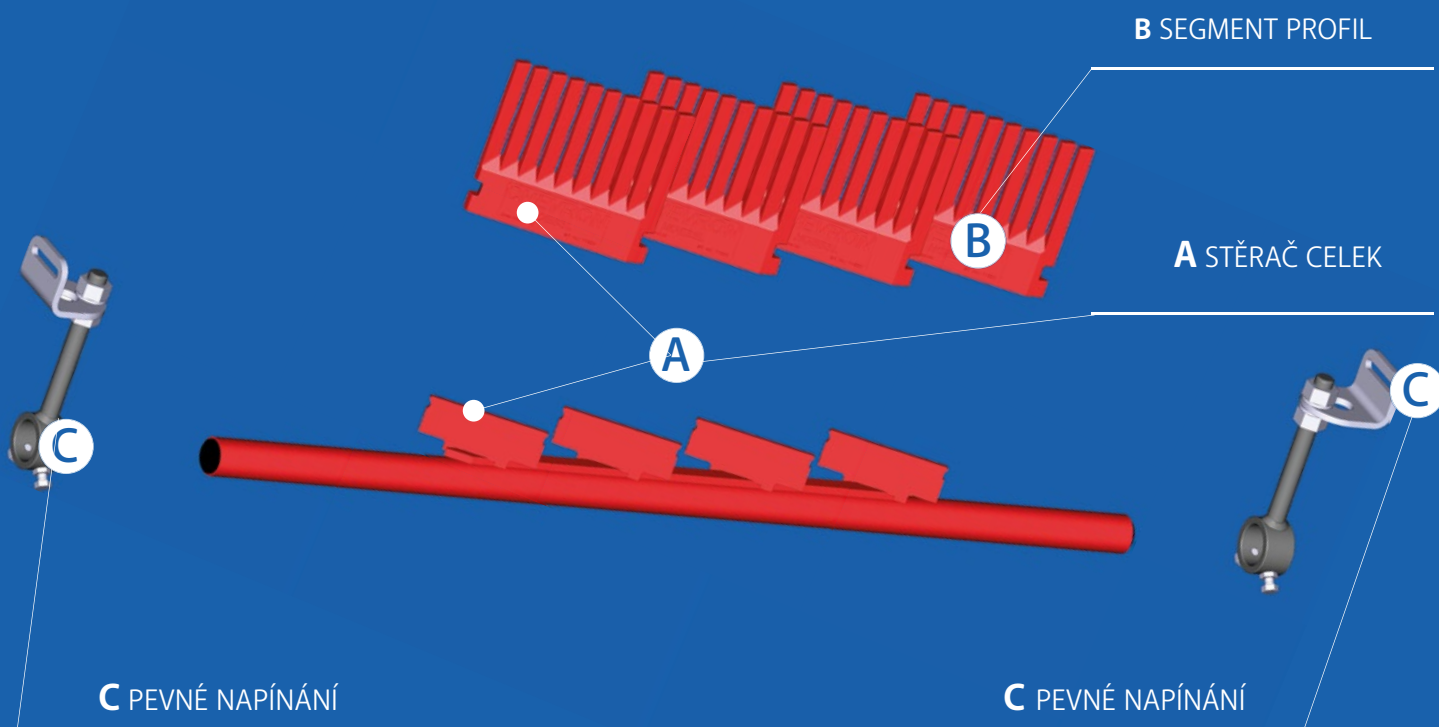

SPODNÍ STĚRAČ DP PROFIL

PARAMETRY

| L1 (mm) | L2 (mm) | L3 (mm) | B segmenty | ø d (mm) | A | B |
|------------|------------|------------|---------------|-------------|----------------|--------|
| 400/500 | 390 | 1 000 | 2 | 48 | 11 810 – 390 | 11 820 |
| 650 | 580 | 1 200 | 3 | | 11 810 – 580 | |
| 800 | 770 | 1 300 | 4 | | 11 810 – 770 | |
| 1 000 | 960 | 1 500 | 5 | | 11 810 – 960 | |
| 1 200 | 1 150 | 1 700 | 6 | | 11 810 – 1 150 | |
| 1 400 | 1 340 | 1 900 | 7 | | 11 810 – 1 340 | |
| 1 600 | 1 530 | 2 100 | 8 | 60 | 11 310 – 1050 | |
| 1 800 | 1 720 | 2 300 | 9 | | 11 310 – 1125 | |
| 2 000 | 1 910 | 2 500 | 10 | | 11 310 – 1200 | |
| | | | | | | |

MONTÁŽNÍ HODNOTY

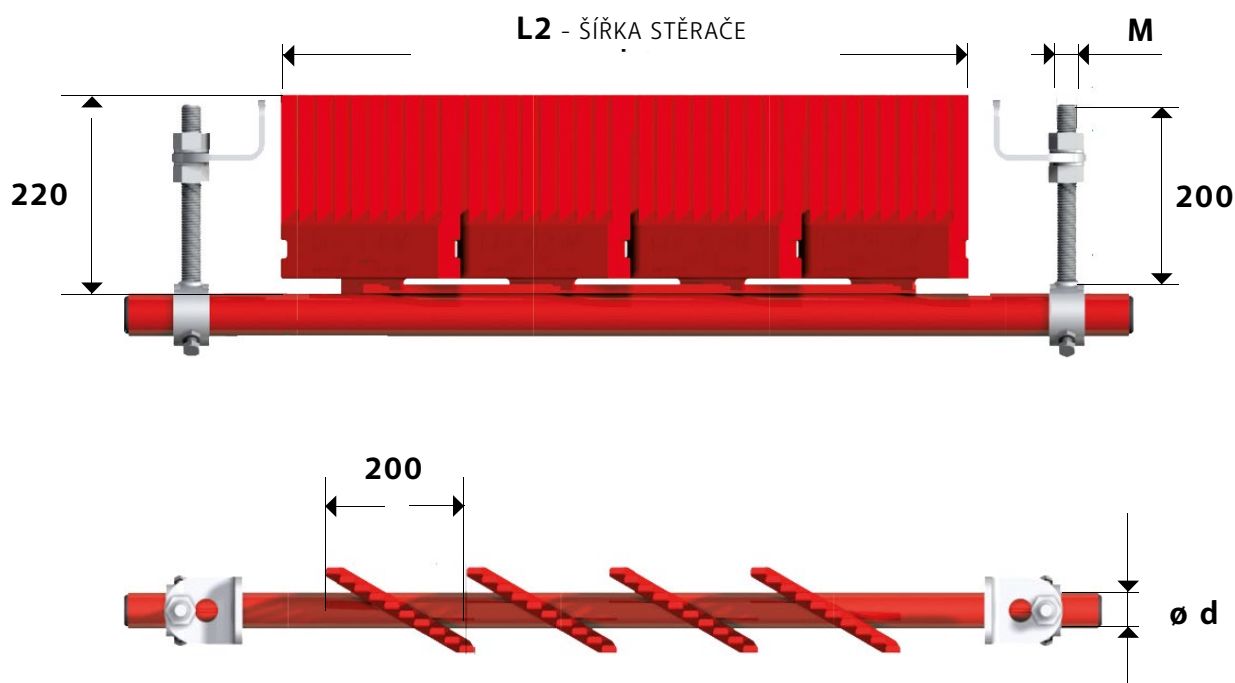

| L2 (mm) | ø d (mm) | M (mm) |
|---------------|-------------|-----------|
| 390 - 1 340 | 48 | 24 |
| 1 530 - 1 910 | 60 | 30 |

VNITŘNÍ STĚRAČ DP **DIAGONAL**

— -30 °C + 80 °C

PEVNÉ NAPÍNÁNÍ STĚRAČE

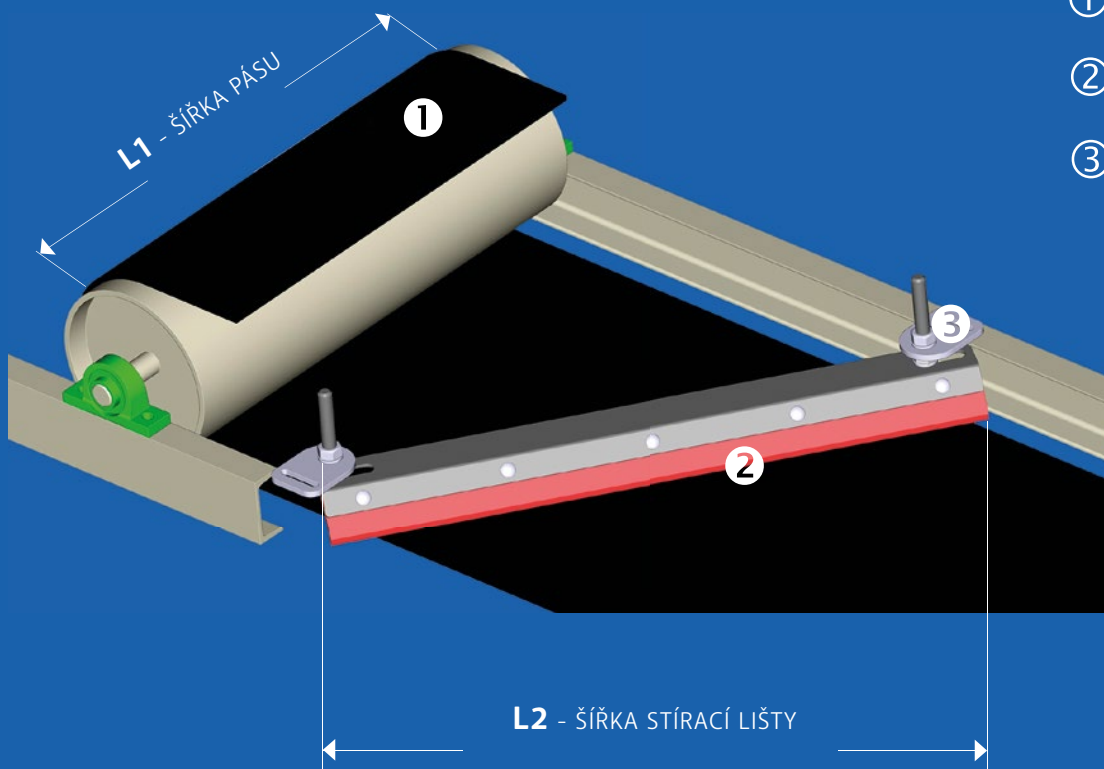

- ① Pásový dopravník
- ② Stěrač celek
- ③ Napínání stěrače

SESTAVA STĚRAČE

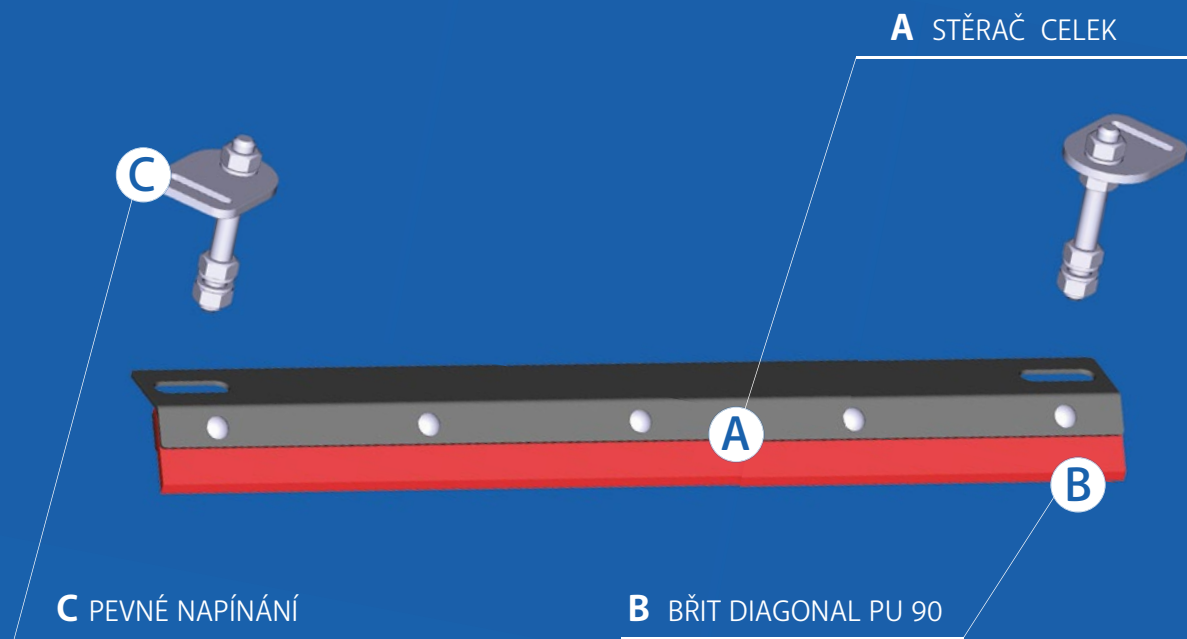

VNITŘNÍ STĚRAČ DP **DIAGONAL**

PARAMETRY

| L1 (mm) | L2 (mm) | A | B |
|------------|------------|----------------|----------------|
| 400 | 450 | 13 150 – 450 | 13 160 – 450 |
| 500 | 550 | 13 150 – 550 | 13 160 – 550 |
| 650 | 700 | 13 150 – 700 | 13 160 – 700 |
| 800 | 850 | 13 150 – 850 | 13 160 – 850 |
| 1 000 | 1 050 | 13 150 – 1 050 | 13 160 – 1 050 |
| 1 200 | 1 250 | 13 150 – 1 250 | 13 160 – 1 250 |
| 1 400 | 1 450 | 13 150 – 1 450 | 13 160 – 1 450 |
| 1 600 | 1 650 | 13 150 – 1 650 | 13 160 – 1 650 |

NAPÍNÁNÍ STĚRAČE - MONTÁŽNÍ HODNOTY

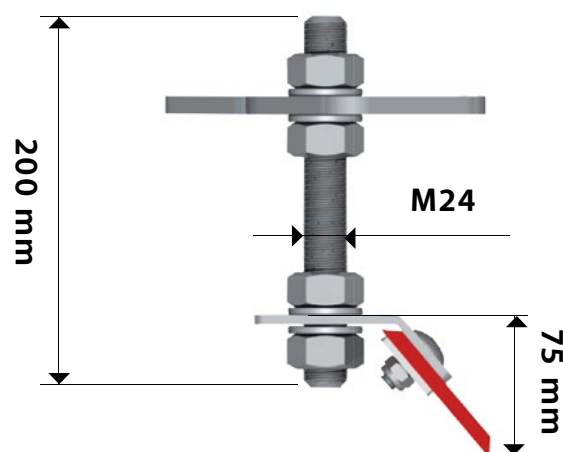
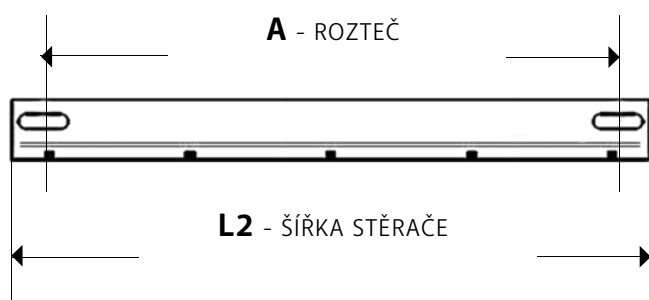

NAPÍNÁNÍ STĚRAČE - UMÍSTĚNÍ NA PÁSU

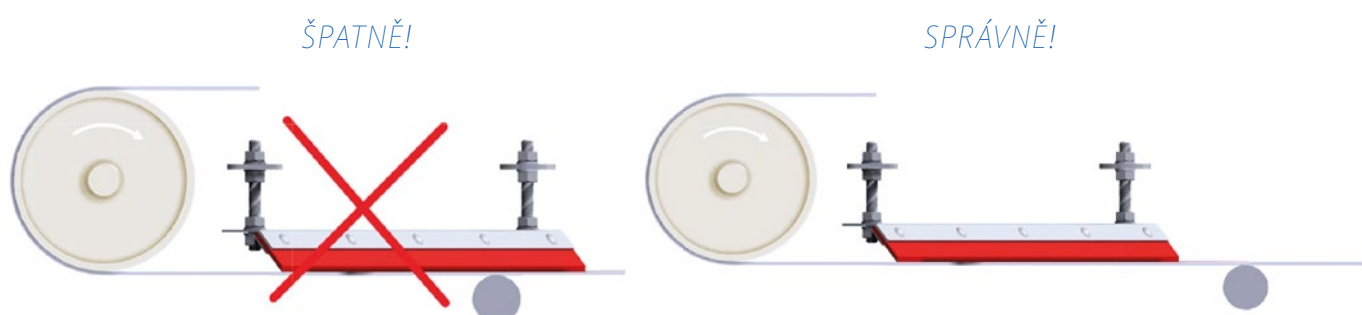

VNITŘNÍ STĚRAČ DP PLUH

−30 °C +80 °C

NAPÍNÁNÍ STĚRAČE

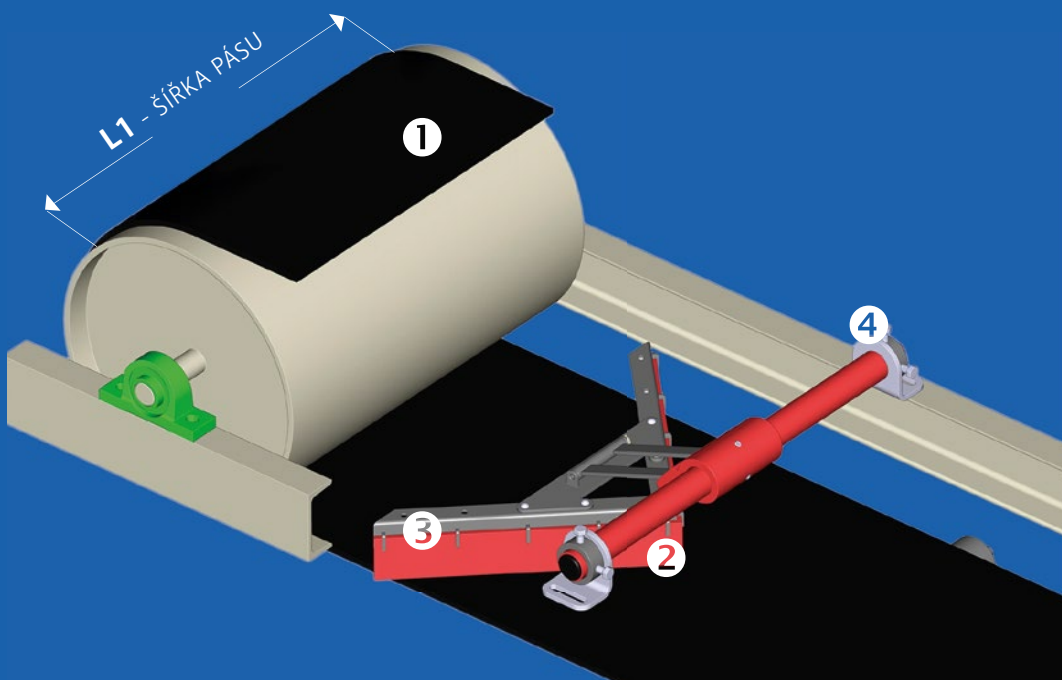

- ① Pásový dopravník
- ② Břit PLUH PU 90
- ③ Stěrač celek
- ④ Napínání stěrače

SESTAVA STĚRAČE

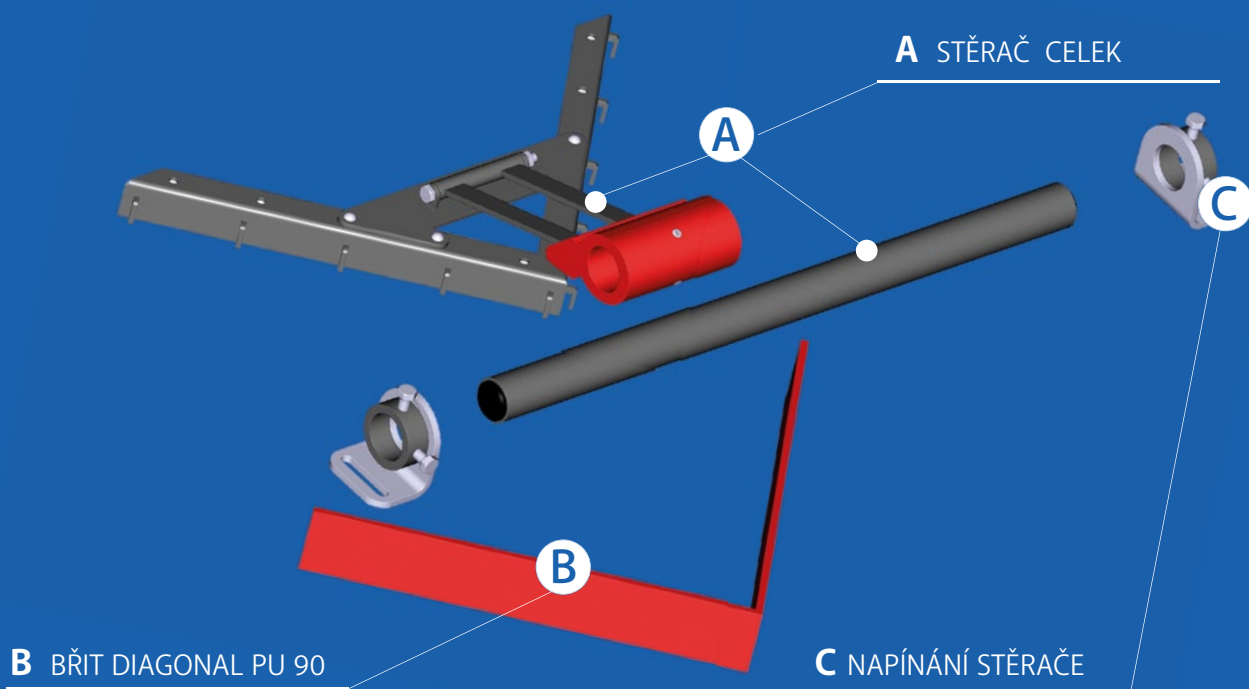

VNITŘNÍ STĚRAČ DP PLUH

PARAMETRY

| L1 (mm) | L2 (mm) | L3 (mm) | ø d (mm) | A | B |
|------------|------------|------------|-------------|-------------------|-------------------|
| 500 | 550 | 800 | 48 | 13 110 P2 – 550 | 11 120 P2 – 550 |
| 650 | 700 | 1 000 | | 13 110 P2 – 700 | 11 120 P2 – 700 |
| 800 | 850 | 1 100 | | 13 110 P2 – 850 | 11 120 P2 – 850 |
| 1 000 | 1 050 | 1 300 | | 13 110 P2 – 1 050 | 11 120 P2 – 1 050 |
| 1 200 | 1 250 | 1 500 | | 13 110 P2 – 1 250 | 11 120 P2 – 1 250 |
| 1 400 | 1 450 | 1 700 | | 13 110 P2 – 1 450 | 11 120 P2 – 1 450 |

NAPÍNÁNÍ STĚRAČE - MONTÁŽNÍ HODNOTY

| L1 (mm) | A (mm) | B (mm) | H1 (mm) | H2 (mm) |
|------------|-----------|-----------|------------|------------|
| 500 | 336 | ~600 | 200 - 350 | 95 |
| 650 | 386 | ~600 | | |
| 800 | 460 | ~650 | | |
| 1 000 | 562 | ~750 | | |
| 1 200 | 670 | ~850 | | |
| 1 400 | 763 | ~950 | | |

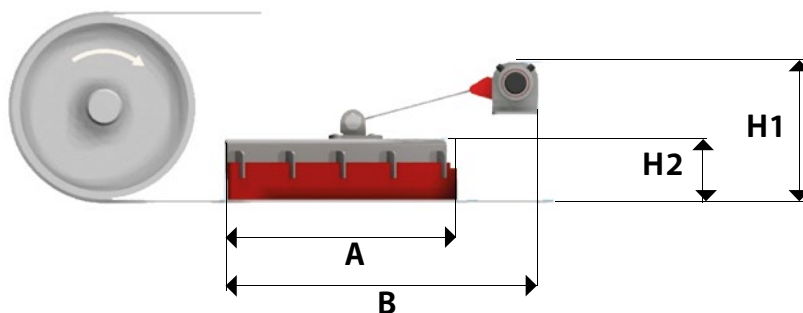

NAPÍNÁNÍ STĚRAČE - UMÍSTĚNÍ NA PÁSU

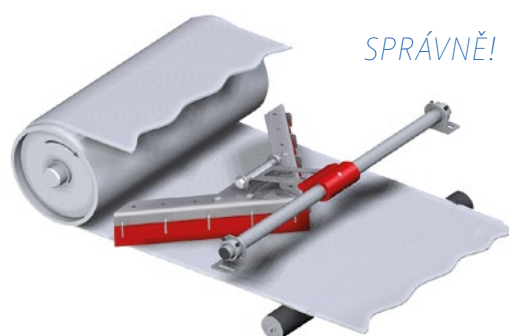

ROST Group, s. r. o.

5. května 381, 440 01 Dobroměřice
www.rostgroup.cz / info@rostgroup.cz

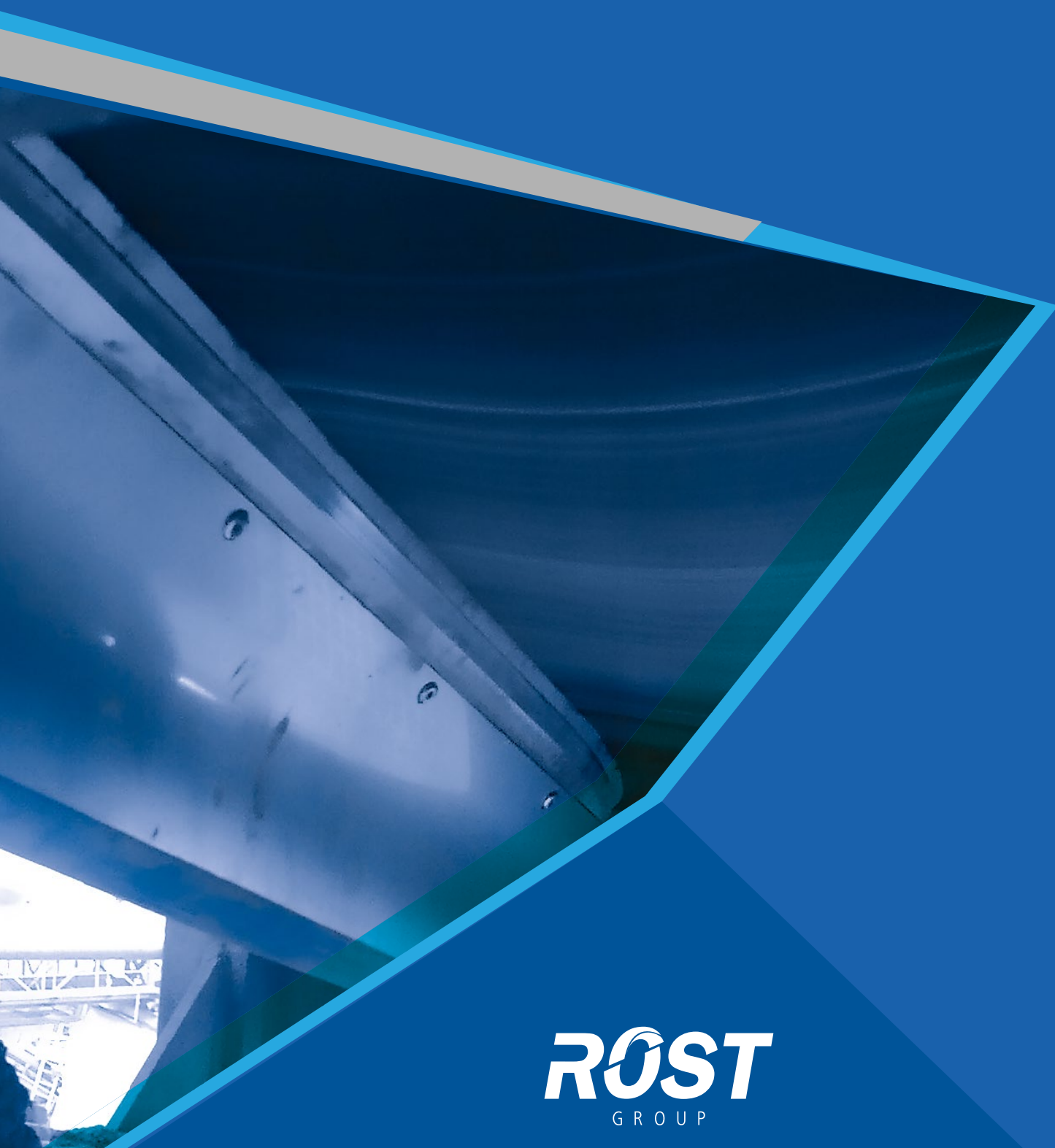

ROST
GROUP

VÝROBA A SERVIS ČISTÍCIHO SYSTÉMU DOPRAVNÍCH PÁSŮ